

TM 11-6625-665-15

DEPARTMENT OF THE ARMY TECHNICAL MANUAL

ORGANIZATIONAL, DS, GS, AND
DEPOT MAINTENANCE MANUAL

GENERATOR SIGNAL AN/USM-205



HEADQUARTERS, DEPARTMENT OF THE ARMY
MARCH 1966

CHANGE }
No. 1 }

HEADQUARTERS
DEPARTMENT OF THE ARMY
WASHINGTON, DC, 10 May 1974

**Operator's, Organizational, Direct Support, General Support, and
Depot Maintenance Manual
GENERATOR SIGNAL AN/USM-205**

TM 11-6625-665-15, 1 March 1966, is changed as follows:

1. A vertical bar appears opposite changed material.
2. Remove and insert pages as indicated in the page list below,:

<i>Remove</i>	<i>Insert</i>
i and 1-10	i through iii (iv blank)
1-1 and 1-2	1-1 and 1-2
AII-1 through AII-3/(AII-4 blank)	None

3. File this change sheet in front of the manual for reference purposes.

By Order of the Secretary of the Army:

CREIGHTON W. ABRAMS
*General, United States Army
Chief of Staff*

Official:

VERNE L. BOWERS
*Major General, United States Army
The Adjutant General*

Distribution:

To be distributed in accordance with DA Form 12-32, Section III, Organizational Maintenance requirements for AN/FPA-15 and AN/FPA-16, and DA Form 12-36, Section I, Organizational Maintenance requirements for AN/AKT-16, AN/APS-94, AN/TKQ-1 and AN/TKQ-2.

OPERATING AND SERVICING MANUAL



MODEL 650A
TEST OSCILLATOR

SERIALS PREFIXED: 233-

ALSO SERIAL PREFIX 203 THRU 025

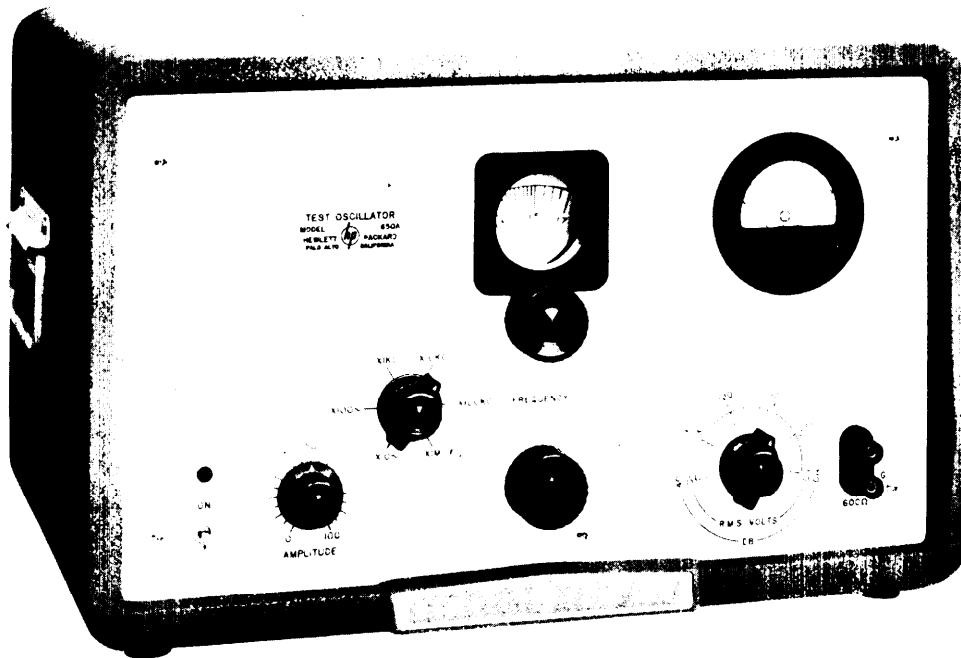

NOTES

TECHNICAL MANUAL }
No. 11-6625-665-15 }

HEADQUARTERS
DEPARTMENT OF THE ARMY
WASHINGTON, DC, 1 March 1966

**Operator's, Organizational, Direct Support, General Support, and
Depot Maintenance Manual**

GENERATOR SIGNAL AN/USM-205

Section	Page
I. GENERAL DESCRIPTION _ _ _ _ _	1-1
1-1 General _ _ _ _ _	1-1
1-2 Indexes of Publications _ _ _ _ _	1-1
1-3 Forms and Records _ _ _ _ _	1-1
1-4 Reporting of Errors _ _ _ _ _	1-1
1-5 Items Comprising an Operable Equipment_ _ _ _ _	1-2
II. OPERATING INSTRUCTIONS _ _	II-1
2-1 Controls and Terminals _ _ _ _ _	II-1
2-2 Operation_ _ _ _ _	II-2
III. CIRCUIT DESCRIPTION _ _ _ _ _	III-1
3-1 Introduction_ _ _ _ _	III-1
3-2 Oscillators_ _ _ _ _	III-1
3-3 Buffer Amplifier _ _ _ _ _	III-2
3-4 AVC Amplifier _ _ _ _ _	III-2
3-5 Output Amplifier_ _ _ _ _	III-3
3-6 Output Monitor_ _ _ _ _	III-3
3-7 Output Attenuator _ _ _ _ _	III-3
3-6 Power Supply _ _ _ _ _	III-3
IV. MAINTENANCE _ _ _ _ _	IV-1
4-1 Cabinet Removal _ _ _ _ _	IV-1
4-2 Lubrication of Tuning Capaci- tor Drive Mechanism _ _ _ _ _	IV-1
4-3 Drive System for Oscillator Tuning Capacitor _ _ _ _ _	IV-1
4-4 Tube Replacement _ _ _ _ _	IV-1
4-5 Miscellaneous Test and Ad- justments_ _ _ _ _	IV-3
4-6 Complete Test Procedure _ _ _ _ _	IV-4
1) Heater and Regulated Power Supply Volt- ages _ _ _ _ _	IV-5
2) Preliminary Low Fre- quency Response Ad- justment_ _ _ _ _	IV-5
3) Low Frequency Oscilla- tor Output Voltage _ _ _ _ _	IV-5
4) Low Frequency Oscilla- tor Distortion _ _ _ _ _	IV-5
5) Low Frequency Output Distortion _ _ _ _ _	IV-6

Section	Page
6) Calibration of Low Frequency Oscillator_-----	IV-6
7) Low Frequency Oscillator Response_-----	IV-7
8) Output Meter Frequency Response Adjustment	IV-7
9) High Frequency Response Adjustment_-----	IV-7
10) High Frequency Distortion Measurement_---	IV-8
11) Check FM at 10 Mc_-----	IV-8
12) Calibration of High Frequency Oscillator_-----	IV-8
13) Calibration of X100KC Range_-----	IV-9
14) Other Adjustments_-----	IV-9
4-7 Troubleshooting_-----	IV-9
4-8 Drive Cable Replacement Procedure_-----	IV-14
V. PREVENTIVE MAINTENANCE SERVICES_-----	V-1

Appendix

II. BASIC ISSUE ITEMS LIST (BIIL) AND ITEMS TROOP INSTALLED OR AUTHORIZED LIST (ITIAL) (Not Applicable)

LIST OF ILLUSTRATIONS

Number	Page
2-1 Schematic Diagram of Output Divider Cable_-----	II-3
3-1 Block Diagram Model 650A_-----	III-0
3-2 Simplified Diagram of High Frequency Oscillator Section_-----	III-2
3-3 Simplified Diagram of High Frequency Oscillator AVC System_-----	III-2
3-4 Simplified Diagram for Power Supply Regulator_-----	III-3
4-1 Lubrication Points for Tuning Capacitor Drive Mechanism_-----	IV-2
4-2 100 Kc Filter_-----	IV-5
4-3 Calibration and Response Check for Low Frequency Oscillator_-----	IV-6
4-4 Equipment for High Frequency Distortion Measurement_-----	IV-8
4-5 Model 650A Top View_-----	IV-10
4-6 Model 650A Bottom View_-----	IV-11
4-7 Installation of Eyelets on Plastic Coated Cable_-----	IV-14
4-8 Exploded Rear View of Drive Cabling_---	IV-15
4-9 Servicing Etched Circuit Boards_-----	IV-16
4-10 Power Supply Section (Schematic)_-----	IV-17
4-11 Oscillator Section (Schematic)_-----	IV-18

LIST OF TABLES

Number	Page
4-1 Tube Complement and Function Chart _ _	IV-3
4-2 Troubleshooting_ _ _ _ _ _ _ _ _ _	IV-12
5-1 Replaceable Parts_ _ _ _ _ _ _ _ _ _	V-1

SPECIFICATIONS

- Frequency Range: 10 cps to 10 mc. Six decade bands.
- Calibration Accuracy: +2%, 10 cps to 100 kc; ±3%, 100 kc to 10 mc including warm-up and ±10% line voltage variation.
- output : 15 milliwatts or 3 volts rms into 600 ohm resistive load 6 volts rms open circuit.
- Output Attenuator: 0 to 50 db in 10 db steps. Accuracy ±1 db, into resistive load of 600 ohms.
- Output Monitor: Vacuum tube voltmeter monitors level at input to attenuator, in volts or dbm. (Zero dbm = 1 mw in 600 ohms.) Accuracy ±5% of full scale reading.
- Frequency Response: Within ±1 db, 10 cps to 10 mc into 600 ohm resistive load.
- Distortion: Less than 1% from 20 cps to 100 kc, less than 2% from 100 kc to 1 mc, approximately 5% at 10 mc.
- Output Impedance: 600 ohms; 300 ohms or 6 ohms when using 65A-16D Output Divider Cable.
- Hum Voltage: Less than 0.5% of output signal with meter at full scale.
- Power Supply: 115/230 volts ±10%, 50-1000 cps, 165 watts.
- Accessory Furnished: Ⓢ 11047A Output Divider Cable (voltage divider).
- Accessories Available: Ⓢ 11000A Cable, two dual banana plugs.
Ⓢ 11001A Cable, dual banana plug to BNC.
- Dimensions: Cabinet Mount: 20-3/4 in. wide, 12-3/4 in. high, 15 in. deep.

Rack Mount:

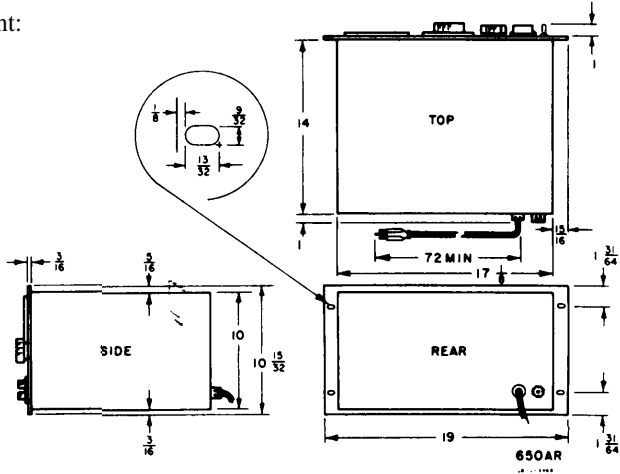

Weight: Cabinet Mount: Net 46 lbs, shipping 55 lbs.
 Rack Mount: Net 37 lbs, shipping 52 lbs.

SECTION II

GENERAL DESCRIPTION

1-1. General

NOTE

Throughout this technical manual, all references to Hewlett-Packard Model 650A Test Oscillator apply to Generator, Signal AN/USM-205.

The purpose of this technical manual is to provide complete instructions for the operation, maintenance, and repair of Generator, Signal AN/USM-205. The Hewlett-Packard Model 650A Test Oscillator is a wide range precision resistance tuned oscillator covering from 10 cps to 10 mc. It has a highly stable output signal level that is adjustable from 30 microvolt to 3 volts into 600 ohms. Frequency response is essentially flat (± 1 db) throughout the complete extended range. The output impedance is normally 600 ohms. Where a low source impedance is desired, 6 ohms is provided by the Voltage Divider Cable supplied with the instrument. The Model 650A Test Oscillator output voltage is constantly monitored by a vacuum tube voltmeter at the input to the output attenuator system. This VTVM has two voltmeter scales plus a dbm scale (0 dbm = 1 milliwatt in 600 ohms). The attenuator control, in conjunction with the AMPLITUDE control, will produce a monitored signal of any desired level when the instrument is resistive loaded with 600 ohms. The flexibility and simplicity of the 650A Test Oscillator find a wide variety of uses in audio, video, rf, and alignment applications as well as laboratory wide band measurements. This instrument was designed for such applications as fast and accurate testing of filter transmission characteristics, tuned circuit response, complete receiver alignment, telephone or telegraph carrier equipment, plus video and audio amplifiers. The Model 650A Test Oscillator is

well suited as a signal source for af and rf bridge measurements. The wide range of test frequencies necessary for repair and testing of electronic frequency counters is also available from the 650A Test Oscillator.

1-2. Indexes of Publication

a. *DA Pam 310-4*. Refer to the latest issue of DA Pam 310-4 to determine whether there are new editions, changes, or additional publications pertaining to the equipment.

b. *DA Pam 310-7*. Refer to DA Pam 310-7 to determine whether there are modification work orders (MWO's) pertaining to the equipment.

1-3. Forms and Records

a. *Reports of Maintenance and Unsatisfactory Equipment*. Maintenance forms, records, and reports which are to be used by maintenance personnel at all maintenance levels are listed in and prescribed by TM 38-750.

b. *Report of Packaging and Handling Deficiencies*. Fill out and forward DD Form 6 (Report of Packaging and Handling Deficiencies) as prescribed in AR 700-58/NAVSUP PUB 378/AFR 71-4/MCO P4030.29, and DSAR 4145.8.

c. *Discrepancy in Shipment Report (DISREP) (SF 361)*. Fill out and forward discrepancy in Shipment Report (DISREP) (SF 361) as prescribed in AR 55-38/NAVSUPINST 4610.33/AFM 75-18/MCO P4610.19A, and DSAR 4500.15.

1-4. Reporting of Errors

The reporting of errors, omissions, and recommendations for improving this publication by

the individual user is encouraged. Reports should be submitted on DA Form 2028 (Recommended Changes to Publications and Blank

Forms) and forwarded direct to Commander, US Army Electronics Command, ATTN: AMSEL-MA-C, Fort Monmouth, NJ 07703.

1-5. Items Comprising an Operable Equipment

<i>FSN</i>	<i>Qty</i>	<i>Nomenclature, part No., and mfr code</i>	<i>Fig. No.</i>
6625-788-9672		Generator, Signal AN/USM-205: Frequency range 10CPS to 10 MC, 6 decade bands: calibration accuracy ±2% 10 COS to 100 KC; ±3% 100 DC to 10 MC: 3 volts RMS maximum output into 600 ohms resistive load ±1 db maximum variation throughout frequency range: output impedance 600 ohms; 300 ohms or 60 ohms when using divider, voltage MX-6122/U: Power requirements; 115/230 vac ±10%; 50 to 1,000 cps; 165 watts: overall dimensions. 20¾ in. lg x 15 in. w x 12¾ in. h which includes:	
5995-985-8214	1	Cable Assembly, Radio Frequency CG-2733/U (4 ft 0 in.)	2-1
6625-759-7436	1	Divider, Voltage MX-6122/U	

SECTION II

OPERATING INSTRUCTIONS

2-1 CONTROLS AND TERMINALS

ON -

This toggle switch controls the power transformer primary circuit. When switch is ON, the calibrated FREQUENCY dial is also illuminated.

FREQUENCY RANGE SWITCH -

This six-position rotary switch has markings of X10 ν , X100 ν , X1KC, X10KC, X100KC, and X1M. The position of this switch indicates the multiplication factor which must be applied to the reading of the FREQUENCY dial to determine output frequency.

FREQUENCY -

Oscillator frequency on any band is determined by rotating the two control knobs under the tuning dial. The upper knob provides coarse tuning while the lower knob provides a 6 to 1 mechanical vernier for fine tuning.

TUNING DIAL -

The tuning dial is accurately calibrated from .9 through 10. The dial reading multiplied by the Frequency Range Switch setting is the instrument output frequency.

R. M. S. VOLTS/DB -

This rotary switch is the output attenuator control which provides signal levels from -40 dbm to +10 dbm in 10 db steps. This switch also indicates voltage across a 600 ohm load connected to output terminals when instrument output is adjusted for a full scale voltmeter indication.

When rotated full clockwise the attenuator is effectively switched out of the circuit.

AMPLITUDE -

This control permits adjustment of input level to the output amplifier and thereby controls instrument output level. Any desired output signal level between the 10 db steps of the R. M. S. VOLTS/DB selector switch can be obtained.

OUTPUT METER -

This meter continuously monitors the signal level when operating into a 600 ohm resistive load. It indicates as a full scale deflection the value of the R. M. S. VOLTS/DB selector switch setting. The meter is indicated as M1 on the schematic diagram and together with V16 and associated components, constitutes the VTVM monitor section.

600 Ω -

The output terminals are universal binding posts on 3/4 inch centers. The output signal is developed between these two terminals with the one marked "G" grounded to the instrument chassis.

FUSE -

The fuseholder, located on rear of chassis, contains a 2 ampere slow-blow fuse for 115 volt operation. If instrument power transformer primary connections have been changed for 230 volt operation, a 1 ampere slow-blow fuse must be used.

POWER CABLE -

The three conductor power cable supplied with this instrument is terminated in a polarized three prong male connector recommended by the National Electrical Manufacturers Association. The third contact is an offset round pin added to a standard two-blade ac plug which grounds the instrument chassis when used with the appropriate receptacle. To use this NEMA plug in a standard two contact outlet an adapter will be required. The ground connection emerges from the adapter as a short lead which should be connected to ground for the protection of operating personnel.

NOTE

This Model 650A Test Oscillator is shipped from the factory with the power transformer dual primary windings connected in parallel for 115 volt operation. If operation from a 230 volt source is desired, primary windings must be reconnected in series as shown in the detail on the schematic diagram. A simultaneous fuse change will also be required.

2-2 OPERATION

The operation procedure for the f_r Model 650A Test Oscillator is as follows:

- a. Connect instrument to power source of 115 volt, 50-1000 cps unless modified for 230 volt operation.
- b. Turn instrument on and, for best results, allow a minimum warm-up time of 15 minutes.
- c. Select desired output frequency by adjusting the Range Switch and FREQUENCY controls,
- d. Connect load to output terminals and adjust for desired output level by setting attenuator switch and AMPLITUDE controls.

Refer to the following paragraphs for specific instructions on setting to a frequency, loading, and use of the output monitor.

SETTING TO FREQUENCY

The frequency of a test signal from the 650A is controlled by the FREQUENCY dial setting and the setting of the Frequency Range Switch.

The FREQUENCY dial is calibrated from .9 through 10. This dial reading multiplied by the setting of the Frequency Range Switch will give the frequency of the output signal.

LOADING AND USE OF INTERNAL VOLTMETER

The internal vacuum tube voltmeter (VTVM) measures the input voltage to an output attenuator system. This output attenuator is the "R. M. S. VOLTS/DB" switch next to the "600 Ω " output terminals in the lower right corner of the front panel. The VTVM has two voltage scales calibrated 0 to 1.0 and 0 to 3 plus a db scale calibrated -12 to +2 dbm (0 dbm = 1 milliwatt into 600 ohms). When using the db scales, the relative output signal level is determined in db by algebraically adding the db setting of the attenuator switch to the db reading of the VTVM.

NOTE

Calibration of the VTVM section is based upon a 600 ohm resistive load being connected to the instrument output terminals. The output divider cable supplied with instrument contains a load of this value. Loads of other values are then connected to either set of terminals on the output divider cable.

When using the voltage scale, the attenuator setting determines the scale to use and also indicates voltage at output terminals when a full scale voltmeter indication is obtained with a 600 ohm load. If VTVM indication is less than full scale, terminal voltage can be determined from the meter indication with the decimal point relocated to agree with the full scale value. This voltage, as indicated by the VTVM reading and the attenuator setting, will be referred to as the "indicated" voltage in the discussion that follows.

SPECIAL CONSIDERATION WITH +10/3.0 ATTENUATOR SETTING

When the "R. M. S. VOLTS/DB" switch is rotated full clockwise (+10/3.0 position), a "straight-through" connection is made in the attenuator to effectively disconnect it from the output system. The actual output voltage will be the same as the indicated voltage as read on the 0 to 3 volt scale. Any value load can be connected to the output terminals and the VTVM will indicate actual output voltage.

CONNECTING A 600 OHM LOAD

A resistive load of 600 ohms may be connected directly to the instrument output terminals. Under these conditions, the indicated voltage will be the voltage at the output terminals.

At higher frequencies, test leads must be short and the shunting capacitance low. At frequencies above approximately 2 mc, if the external shunt capacitance is high, use of the "6 Ω VOLTAGE X.01" terminals of the Output Divider Cable is recommended.

OUTPUT DIVIDER CABLE

The Output Divider Cable contains two resistors connected in series to provide a load of 600 ohms as shown in Figure 2-1. The first resistor (594 ohms) is mounted in the connector for the instrument output terminals. The second resistor (6 ohms) is mounted at the output end of the cable. These two resistor values provide a 100 to 1 (-40 db division ratio and a source impedance of 6 ohms at the output end of the cable.

- a. "600 Ω LOAD" Terminals -
The terminals marked "600 Ω LOAD" at the input end of the output cable are in parallel with the instrument "600 Ω " output terminals. With

attenuator in +10/3.0 position, output voltage at "600 Ω LOAD" terminals will be the same as the indicated voltage.

Internal impedance is 300 ohms with output divider cable connected. The voltage available at the "600 Ω LOAD" terminals will depend upon the value of the applied resistive load.

The actual voltage (E_a) available at the "600 Ω LOAD" terminals with a resistive load (R in ohms) can be calculated from the indicated voltage (E_i) as follows:

$$E_a = E_i \times \frac{R}{R + 300}$$

- b. "6 Ω VOLTAGE X.01" Terminals -
These output terminals are recommended

whenever the load has high distributed capacity or a low value. Loads from 6 ohms and up may be connected here.

The actual voltage available from these terminals is 1/100 of the indicated voltage provided the load resistance is very high with respect to 6 ohms.

The actual voltage (E_a) available at the "6 Ω VOLTAGE X.01" terminals with a resistive load (R in ohms) can be calculated from the indicated voltage (E_i) as follows:

$$E_a = E_i \times \frac{1}{100} \times \frac{R}{R + 6}$$

If the load resistance is 6 ohms, the actual voltage will be 1/200 of the indicated voltage.

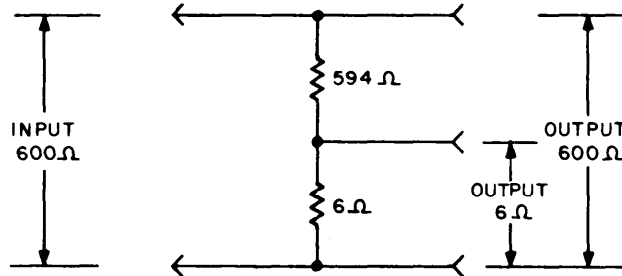
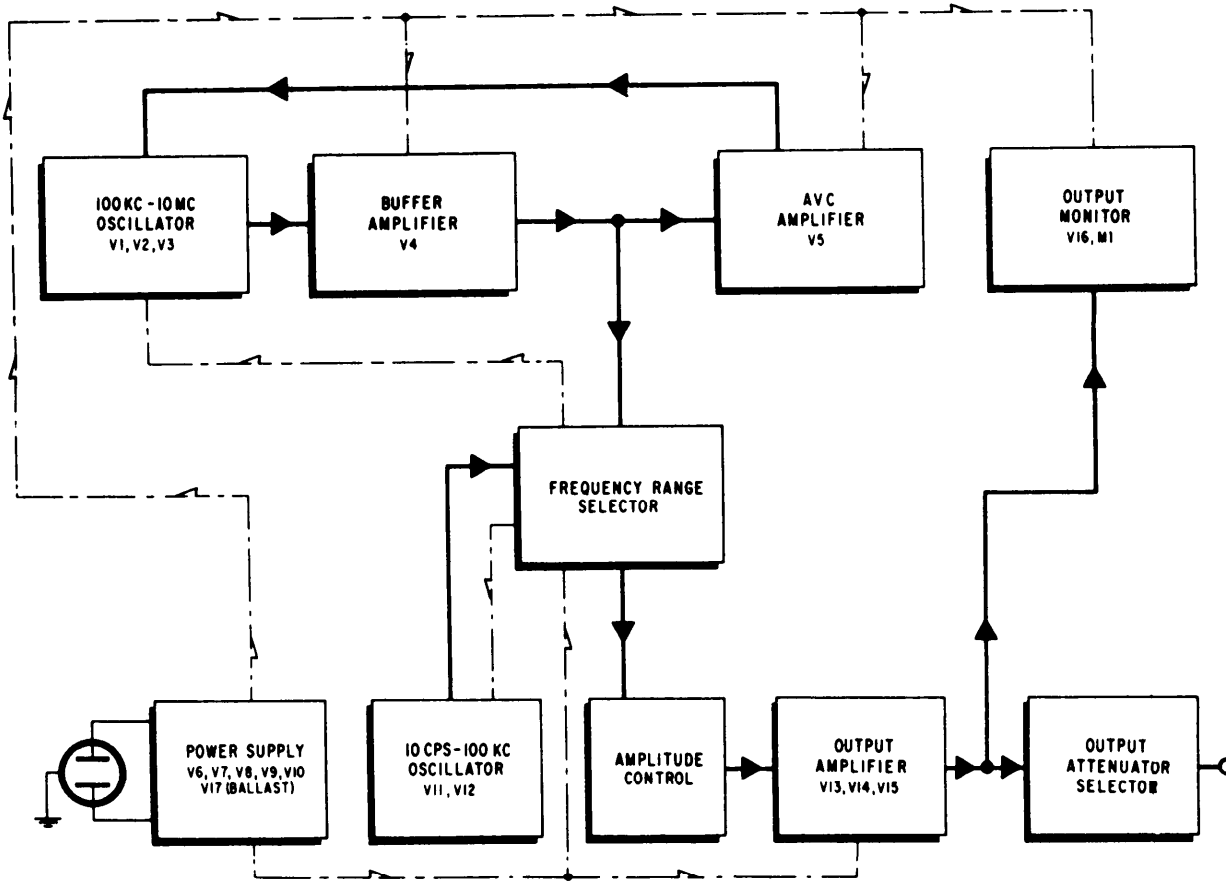

Figure 2-1. Schematic Diagram of Output Divider Cable



BD-S-27

Figure 3-1. Block Diagram of Model 650A Test Oscillator

SECTION III

CIRCUIT DESCRIPTION

3-1 INTRODUCTION

The Model 650A Test Oscillator circuitry can be divided into several basic circuits as shown in Figure 3-1. A discussion of these basic circuits will be found in the following paragraphs:

- 3-2 Oscillators
- 3-3 Buffer Amplifier
- 3-4 AVC Amplifier
- 3-5 Output Amplifier
- 3-6 Output Monitor
- 3-7 Output Attenuator
- 3-8 Power Supply

3-2 OSCILLATORS

Two oscillators are used to cover the frequency range from 10 cps to 10 mc. The low frequency oscillator covers from 10 cps to 100 kc in four ranges while the high frequency oscillator covers from 100 kc to 10 mc in two ranges.

Each oscillator section is separate and complete. The Frequency Range Switch allows only one oscillator to function at a time by automatically switching B+ to the desired oscillator section. It is recommended that if the instrument is to be on for long periods of time when not in actual use, that the Frequency Range Switch be left in one of the four lower ranges so that the high frequency oscillator will not be operating.

LOW FREQUENCY OSCILLATOR

The low frequency oscillator is used to cover frequencies from 10 cps to 100 kc and consists of tubes V11 and V12. These two tubes are connected as a two-stage amplifier in which a positive feedback loop in conjunction with an r-c network controls the frequency of oscillation.

The tubes must be operated over the linear portion of their characteristics in order to provide a sine wave output. A negative feedback loop is necessary

for this purpose. The 10 watt incandescent lamp (R80) has a positive temperature coefficient and is part of the negative feedback loop. This lamp regulates the amount of negative feedback in accordance with the amplitude of oscillation to maintain a constant output level with minimum distortion over the low frequency oscillator range.

The oscillator is adjusted for optimum performance by adjustment of resistor R46 in the negative feedback loop. Resistor R53 is used to set the low frequency oscillator input signal level to the AMPLITUDE control equal to the signal level from the high frequency oscillator. The procedure for adjustment of these controls will be found in the MAINTENANCE section of this manual.

REFERENCES

Bauer, B. "Design Notes on the Resistance Capacity Oscillator Circuit", Hewlett-Packard Journal, November - December, 1949.

Terman, F. E. Radio Engineers Handbook, McGraw Hill Book Co., New York, 1943. Pages 504-506.

Edson, W. A. Vacuum Tube Oscillators, John Wiley & Sons, Inc., New York, 1953. Pages 138-142.

HIGH FREQUENCY OSCILLATOR

The high frequency oscillator consists of V1, V2, and V3 in an r-c phase shift oscillator. A simplified schematic diagram of this circuit is given in Figure 3-2.

The phase shift network on the 1 to 10 mc range consists basically of plate load resistors R3, R4, and R6 plus C1A, C1B and C1C sections of the tuning capacitor that shunt the grid circuits. The resistor and capacitor values produce a phase shift of 60 degrees at the frequency of oscillation. This shift is in addition to the 180 degree shift taking place from the grid to the plate of each tube which produces a total shift of 240 degrees for each tube. Three networks of this nature provide a 720 degree phase

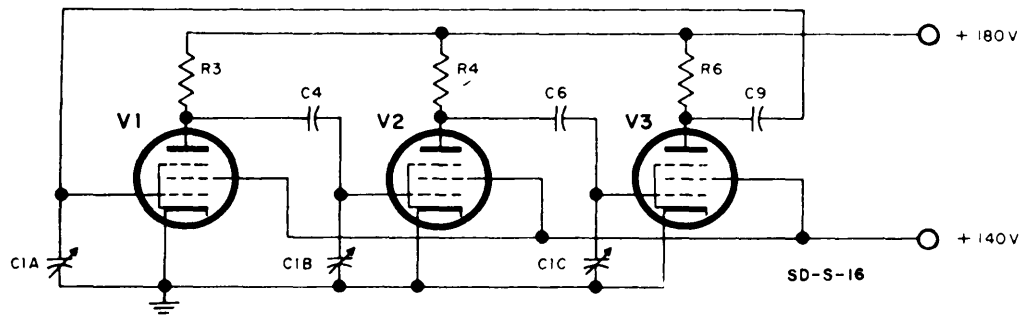

Figure 3-2. Simplified Diagram of High Frequency Oscillator Section

shift between the output of the third oscillator tube and the grid of the first oscillator tube. This condition makes the feedback signal in phase with the grid signal on V1 and oscillation occurs. Locating the phase shift networks between the oscillator tubes rather than in cascade permits the tube capacitance to be employed as part of the phase shift network.

On the 100 kc to 1 mc range an additional series resistance, not shown in the simplified diagram, is switched into the coupling circuits between the tubes which causes the phase shift to take place at one-tenth the frequency of the highest range.

These additional resistors, as well as the plate load resistors, are precision composition type which are factory matched and selected. Occasionally, small low value resistors are placed in the circuit to compensate for slight tolerances of the precision resistors.

Calibration adjustments are provided for the high frequency end of both ranges of the high frequency oscillator. The trimmer capacitors on the three sections of tuning capacitor C1 are adjusted at 10 mc. Ceramic capacitor C3 in the grid circuit of V1 is adjusted at 1 mc with the Frequency Range Switch in the " X100KC" position.

3-3 BUFFER AMPLIFIER

The signal from the high frequency oscillator tubes is fed into the buffer amplifier stage V4 which isolates the high frequency oscillator from the amplitude control circuit and the AVC Amplifier stage V5.

3-4 AVC AMPLIFIER

The AVC Amplifier shown in the simplified schematic of Figure 3-3 is driven by buffer stage V4.

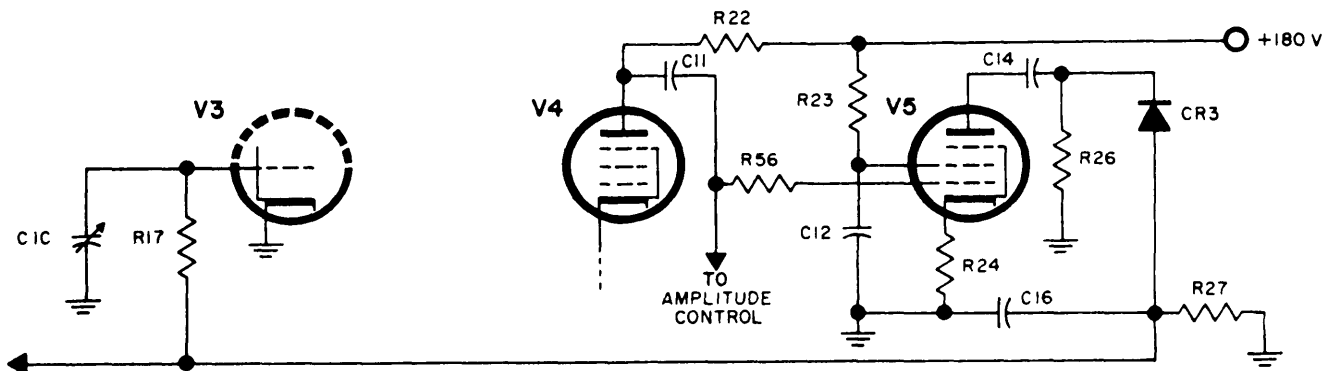

Figure 3-3. Simplified Diagram of High Frequency Oscillator AVC System

The output signal from V5 is rectified by germanium diode CR3 and is then used as grid bias for V1, V2, and V3. This maintains a constant output from the oscillator as well as the buffer stage V4 which is inside the AVC loop.

3-5 OUTPUT AMPLIFIER

The signal voltage from the AMPLITUDE control (R55) is amplified by a three stage feedback amplifier (V13, V14, and V15).

The output amplifier is stabilized with a negative feedback loop in the form of common cathode circuit for V13 and V15. In addition, the transconductance (Gm) of V13 and V14 is stabilized by local dc degenerative feedback. Thus, the amplifier has uniform gain and low distortion over the frequency range from 10 cps to 10 mc.

An adjustment (C38) is provided for adjusting the frequency response at 10 mc.

3-6 OUTPUT MONITOR

The Output Monitor section consists of a single stage voltage amplifier followed by a full wave average reading type voltmeter using germanium crystal diodes as rectifiers. The indicating meter has a basic zero to one milliamper movement.

The voltage amplifier V16 obtains an input signal from the last stage of the Output Amplifier before the signal enters the output attenuator system. Hence, instrument loading is important when using the readings obtained on the output monitor meter to determine actual output voltage. The use of the output voltmeter is fully explained in paragraph 2-2

under the heading of LOADING AND USE OF INTERNAL VOLTMETER.

Variable capacitor C42 can be set to adjust the voltmeter frequency response at 10 mc. Resistor R77 is an additional calibration adjustment which is set at 1000 cps before adjusting capacitor C42 at 10 mc.

3-7 OUTPUT ATTENUATOR

The Output Attenuator is a five section "T" structure designed to have 50 db of attenuation in five steps of 10 db each when operated into a resistive load of 600 ohms. The attenuator is frequency compensated for maximum accuracy over the instrument frequency range.

Use of the output attenuator is fully explained in paragraph 2-2 under the heading of LOADING AND USE OF INTERNAL VOLTMETER.

3-8 POWER SUPPLY

All stages of the Model 650A Test Oscillator are supplied with regulated B+ from the internal power supply. In addition, heater voltage for tubes V1, V2, V3, V4, and V16 is regulated by an Amperite type 12-4 ballast tube.

The power transformer has a dual primary winding that may be connected for operation from 115 or 230 volts. The power line frequency may be from 50 to 1000 cps. Power requirements are approximately 165 watts.

A 5U4GA/B full wave rectifier (V10) is followed by a capacitor input L-C filter network. The output of this pi filter goes to the regulator which is shown in simplified form in Figure 3-4.

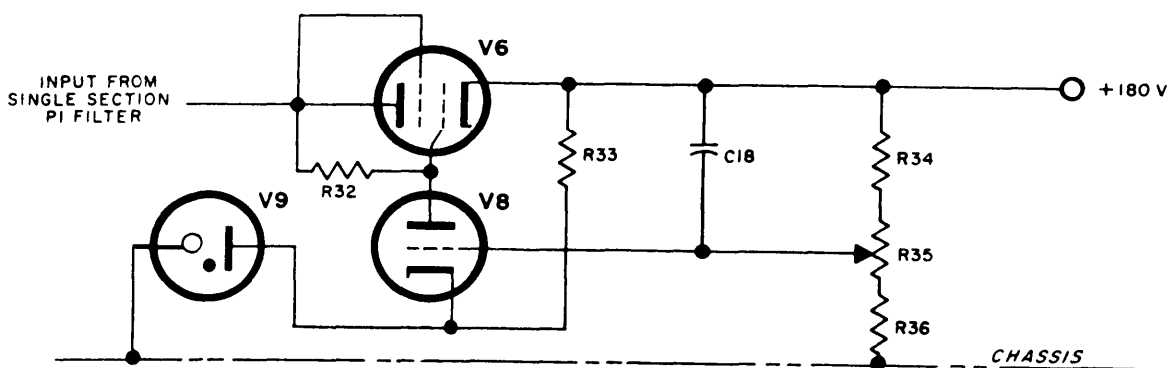

Figure 3-4. Simplified Diagram for Power Supply Regulator

9D-S-13

The cathode of the regulator control tube V8 is maintained at a constant potential by resistor R33 and regulator tube V9. Series regulator tubes V6 and V7 act as variable resistors whose resistances controlled by the grid bias applied to them by control tube V8.

If the regulated B+ voltage at the cathode of V6 were to increase, the grid voltage of V8 would be increased a proportional amount. Tube V8 would then draw more plate current and the voltage drop across R32 would increase. This would result in a more negative grid voltage for V6 whose plate resistance would then increase. The increase resistance of V6 would cause a greater drop across V6 and the output voltage would drop to compensate for the original increase.

If the regulated B+ voltage tends to decrease, the reverse of the above action occurs. In either case, the voltage at the cathodes of the series regulator tubes is maintained at a constant level.

Ripple in the output voltage is coupled to the grid of V8 by capacitor C18. Variations in the dc voltage are coupled to the grid of V8 through the voltage divider consisting of R34, R35, and R36. The bias for V8, and consequently the regulated dc output voltage, is determined by the setting of R35.

The heater supply for High Frequency Oscillator tubes V1, V2, V3, Buffer Amplifier V4, and Voltmeter Amplifier tube V16 is regulated by means of a ballast tube.

The ballast tube has a high positive temperature coefficient. If the voltage applied to the heater circuit were to increase, current through the circuit and ballast tube V17 would also increase. This increased current would cause V17 resistance to increase which would cause the regulated voltage applied to the tubes to decrease and compensate for the initial increase. The reverse action would take place if the voltage applied to the heater circuit were to decrease.

The current through the ballast tube, and thereby the voltage applied to the tubes, can be set by adjusting control R42.

DO NOT remove any of tubes V1, V2, V3, V5, or V16 while the instrument is turned on. The current regulating properties of the ballast tube will apply a higher than normal voltage to the heaters of the remaining tubes operating from this regulated supply. A burned out tube may result.

SECTION IV MAINTENANCE

4-1 CABINET REMOVAL

The two piece cabinet can be easily and quickly removed as follows:

- a. Remove rear cabinet cover after unscrewing four sheet metal screws holding cover.
- b. Place instrument with front control panel up.
- c. Loosen two 3-16 inch Allen screws located on bottom of cabinet adjacent to front feet.
- d. Lift cabinet from instrument.

CAUTION

Do not change settings of trimmer capacitors mounted on or near tuning capacitor gangs. These trimmers affect both calibration and frequency response. Adjust these capacitors only when proper test equipment is available and according to instructions contained in this manual.

4-2 LUBRICATION OF TUNING CAPACITOR DRIVE MECHANISM

The tuning capacitor drive mechanism requires monthly lubrication if instrument is in constant use. Remove dirt or dust with a moderate air stream and place one drop of lubricant at two points as shown in Figure 4-1. Recommended lubricant is "Lubriplate #3" (Fiske Bros. Refining Co., Newark, N.J.) or equivalent.

4-3 DRIVE SYSTEM FOR OSCILLATOR TUNING CAPACITOR

The two oscillator tuning capacitors effectively have a common shaft since their shafts are mechanically connected by a short supported shaft and two flexible couplings. SETSCREWS IN COUPLINGS MUST NOT BE LOOSENED. If shafts of tuning capacitors are

allowed to rotate with respect to each other, frequency dial calibration will be lost. It may be necessary to return instrument for factory recalibration.

The front panel FREQUENCY controls are coupled to the oscillator tuning capacitor shafts by means of a wire cable arrangement. This cable drive system has a designed life expectancy greater than the electrical portion of instrument and will normally require no maintenance.

If cable drive system damage does occur, cable replacement can be accomplished by following directions in paragraph 4-8.

4-4 TUBE REPLACEMENT

Tubes in an Φ Model 650A Test Oscillator can be replaced without special considerations with certain exceptions. Table 4-1 gives recommended tube replacements and tube functions. Instructions for selecting tubes, when required, along with any adjustments or test necessary after replacing a certain tube are given in the following paragraph.

CAUTION

Power to instrument must be turned off prior to removing any of tubes V1, V2, V3, V4, or V16. This precaution will prevent ballast tube current regulator action from burning out heaters of remaining tubes.

- a. REPLACEMENT OF V1, V2, V3, V4 OR V5
Only type 5654 tubes are recommended for replacement of these five tubes. Although not critical, improved performance will be obtained from low microphonics tubes.

After replacement of all or any one of these five tubes, frequency response and calibration of the high frequency oscillator should be checked. It will

also be necessary to check output level, distortion, and frequency modulation of this oscillator and balance oscillator output levels by adjusting R53.

b. REPLACEMENT OF V6, V7, V8, V9 OR V10

Any tube with standard EIA characteristics may be used. It will be necessary to check and set power supply regulated output voltage to 180 volts. It is also advisable to check for hum in output of instrument and test line voltage response.

c. REPLACEMENT OF V11 OR V12

Any tube with standard EIA characteristics may be used. Tubes selected for low microphonics

and low heater to cathode leakage are preferred. Replacement tubes may introduce minor distortion or slightly change frequency dial calibration near 100 kc.

After tube replacement, set low frequency oscillator amplitude at 1000 cps by adjusting R46. Adjust control R46 to set voltage at junction of R47, R54, and C28. Check distortion at this same point when tuned to 100 cps. Check hum level in instrument output and adjust R53 to balance output levels of both oscillators.

d. REPLACEMENT OF V13 OR V14

Check instrument frequency response, hum, distortion, and output level following tube replacement.

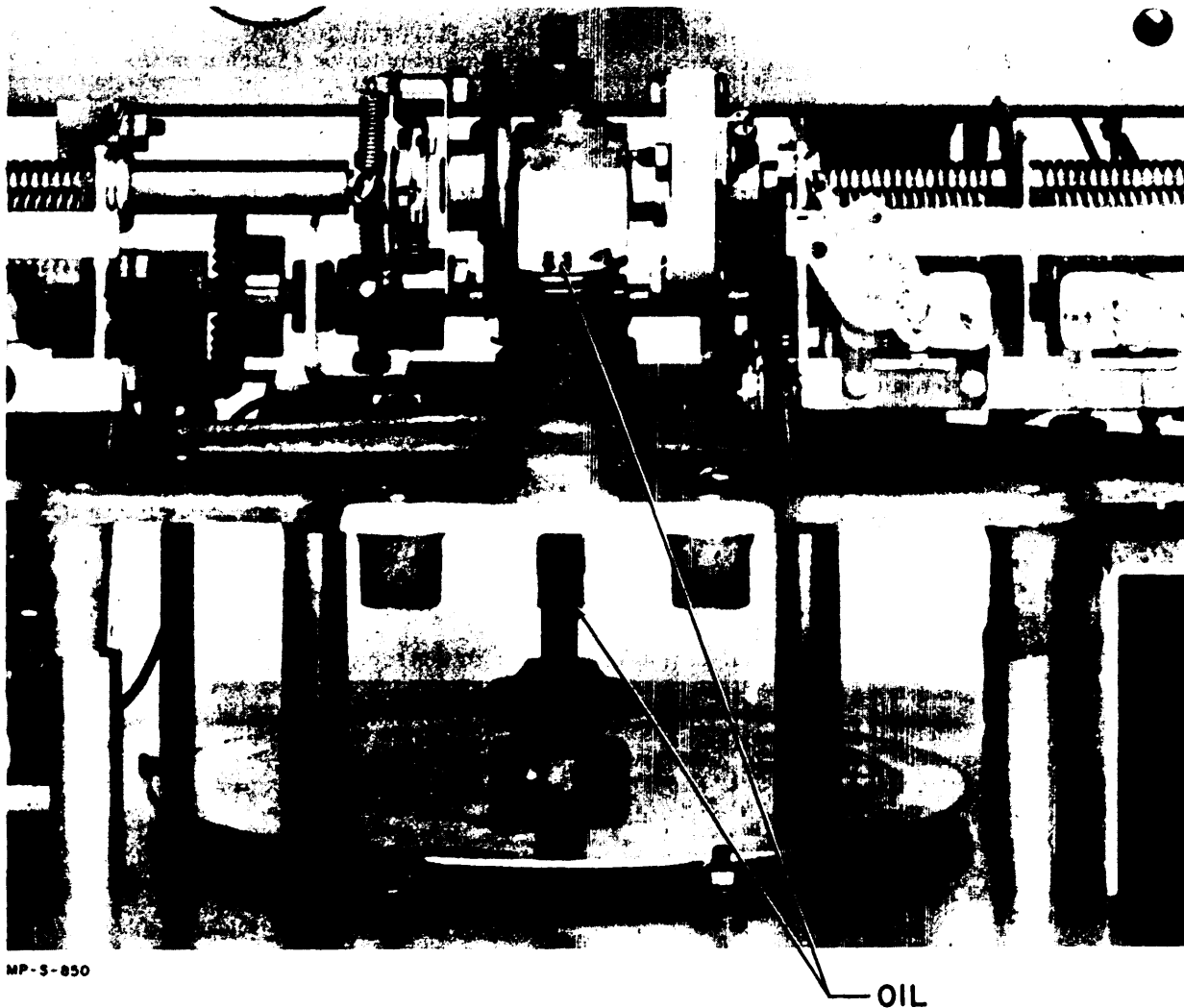

Figure 4-1. Lubrication Points for Tuning Capacitor Drive Mechanism

e. REPLACEMENT OF V15

A tube with standard RETMA characteristics can be used. Check instrument frequency response. Adjust capacitor C38 to set the 1 to 10 mc response.

Instrument hum, distortion, and output level should also be checked.

f. REPLACEMENT OF V16

Adjustment of meter calibrating shunt R77 will probably be necessary. Capacitor C42 is adjusted to flatten voltmeter frequency response in the 1 to 10 mc range.

CAUTION

Do not operate instrument with this tube removed. Turn instrument off before removing tube V16 to prevent possible meter damage.

g. REPLACEMENT OF V17

After replacing ballast tube, adjust control R42 to set heater voltage for V1, V2, V3, V4, and V16.

h. REPLACEMENT OF LAMP R80

Lamp R80 in the low frequency oscillator operates at a low power level resulting in long life with replacement seldom necessary.

After replacing a lamp, measure ac voltage at junction of R47, C28, and R54 with instrument tuned to 1000 cps. This oscillator voltage should be between 18 and 22 volts with approximately 19 volts being optimum in most instruments.

Large deviations from this voltage should be corrected by successive trials of new lamps. Small deviations can be corrected by adjusting control R46.

TABLE 4-1. TUBE COMPLEMENT AND FUNCTION CHART

Circuit Ref.	Tube Type	Tube Function
V1,2,3	5654	High Frequency Oscillator
V4	5654	Buffer Amplifier
V5	5654	AVC Amplifier
V6,7	6L6GB	Power Supply Series Regulator
V8	6SQ7	Power Supply Regulator Control
V9	0A3	Power Supply Voltage Reference
V10	5U4GB	Power Supply Full Wave Rectifier
V11	6SJ7	Low Frequency Oscillator
V12	6AG7	Low Frequency Oscillator
V13	6EW6	Output Ampl. First Stage
V14	6EW6	Output Ampl. Second Stage
V15	6AG7	Output Ampl. Final Stage
V16	5654	Output Voltmeter Ampl.
V17	12-4	Heater Current Regulator

After adjusting oscillator level, balance output levels of two oscillators and check distortion of low frequency oscillator. If instrument seems to be unstable when switching between low frequency oscillator ranges, adjust R46 for a slightly higher oscillator level and repeat test.

Some lamps are highly microphonic and are not usable even though they perform satisfactorily in every other way.

4-5 MISCELLANEOUS TESTS AND ADJUSTMENTS

The following independent tests and adjustments can be made at any time. If an instrument is undergoing a complete test procedure, these tests and adjustments are performed in the sequence given in the complete test procedure. Use output cable supplied with instrument for a 600 ohm resistive load.

a. SETTING V1, V2, V3, V4 AND V16 HEATER VOLTAGE

Set line voltage to 115 volts. Adjust control R42 to obtain 6.3 volts ac at pin 2 of V17 ballast tube. This voltage should not change by more than ± 0.3 volts when line voltage varies $\pm 10\%$.

b. SETTING REGULATED POWER SUPPLY

Connect a dc voltmeter between ground and cathode pin 8 of series regulator tube V6 or V7. Set dc output voltage to 180 volts by adjusting control R35 with line voltage set to 115 volts.

Check regulator line voltage response by varying line voltage $\pm 10\%$ from 115 volts. The regulated dc output should not vary more than 2 volts.

c. BALANCING OSCILLATOR OUTPUT LEVELS

Load instrument with 600 ohms and adjust for a 100 kc output signal on the "X100KC" position. Adjust AMPLITUDE control R55 for a convenient reference point on the output meter.

Switch to 100 kc on the "X10KC" range and adjust R53 for the same output meter reference reading. Control R53 is mounted on the tuner drive casting on the underside of the chassis. See Figure 4-6.

d. CHECK OUTPUT HUM LEVEL

Place a resistive load of 600 ohms and an external ac voltmeter across output terminals. Switch to the "X10KC" range, unscrew lamp R80, and rotate AMPLITUDE control full counterclockwise. Hum voltage should not exceed 0.015 volts (0.5% of 3.0 volt rated output).

e. OUTPUT METER SENSITIVITY ADJUSTMENT

Turn panel AMPLITUDE control full counterclockwise. Set the 650A output meter mechanical adjustment to zero. Connect an external ac voltmeter of known accuracy at 1000 cps and a resistor of 600 ohms across instrument output terminals.

Set AMPLITUDE control for a 3 volt reference reading on external voltmeter with output attenuator set to 3.0 volts and instrument tuned to 1000 cps. Adjust control R77 for a 3 volt reading on internal voltmeter. Check at 2 volts and at 1 volt.

f. ATTENUATOR CHECK

The output attenuator can be checked against a standard 600 ohm attenuator and reference ac voltmeter or with only a vacuum tube ac voltmeter such as $\text{\textcircled{P}}$ Model 400D/H/L.

When using only a vacuum tube voltmeter, connect a resistive load of 600 ohms across output terminals. Check at 1 kc and at 2 mc if a 400C is used and also at 4 mc if a 400D or 400H voltmeter is used.

g. CHECK FOR 60 CPS BEAT

Tune to approximately 55 cps and adjust AMPLITUDE control for an approximate indication of 0.9 full scale on output meter. Slowly tune up through 60 cps and note amount of greatest meter swing. The total maximum swing should not exceed 4% of the full scale value. See paragraph 4-7.

h. INSTRUMENT RESPONSE TO LINE VOLTAGE

Set output voltage at 10 cps to a reference level on 650A output meter. Vary line voltage from 105 to 125 volts. The output meter indication should not change more than 2% of full scale. If out of specifications, repeat check using an external voltmeter to determine if poor response is caused by the amplifier or the output meter circuit.

i. OUTPUT IMPEDANCE

Set output attenuator to the 3 volt or +10 db range and tune instrument to approximately 1000 cps. Adjust AMPLITUDE control to obtain a full scale (3 volts) output meter indication with no load connected to output terminals. The meter indication should drop to half scale (1.5 volts) when a 600 ohm resistive load is connected to the output terminals.

j. MAXIMUM OUTPUT VOLTAGE

Maximum output voltage to a 600 ohm resistive load should be at least 3 volts at all frequencies.

If output is low, increase high frequency oscillator output and balance oscillator output levels. See high frequency oscillator adjustment procedure given in test procedure section.

4-6 COMPLETE TEST PROCEDURE

The following test equipment will be required:

- a. An ac vacuum tube voltmeter with known frequency response from 10 cps to 10 mc. $\text{\textcircled{P}}$ Models 3400A and 410C are suitable for this purpose.
- b. A distortion analyzer such as $\text{\textcircled{P}}$ Model 330B/C/D.
- c. A means of constant line voltage control from 100 to 130 volts.
- d. A dc voltmeter for setting 180 volt output from regulated supply.
- e. Frequency determining equipment covering 10 cps to 10 mc range. An oscilloscope and frequency standard such as $\text{\textcircled{P}}$ Model 100 Series would be suitable for frequencies up to 100 kc. A crystal calibrator could then be used over the 100 kc to 10 mc range. A single electronic frequency counter such as $\text{\textcircled{P}}$ Model 524 Series could also be used to determine frequency over the 10 cps to 10 mc range in place of the above equipment.
- f. An oscilloscope such as $\text{\textcircled{P}}$ Model 160E or 175A.

g. Elimination filter for 100 kc as shown in Figure 4-2. Any coil and capacitor combination can be used that will resonate at 100 kc. If a different inductor is used, the value of the balance control and series resistor will have to be changed. The inductor shown in Figure 4-2 can be obtained under stock No. 9140-0002.

Refer to Figures 4-10 and 4-11 for circuit references unless otherwise designated. All ac or dc voltages are measured between the indicated point and chassis ground.

NOTE

The "R. M. S. VOLTS/DB" output attenuator switch must always be in the "+10/3.0" position unless otherwise instructed.

A complete test requires completion of all of the following tests in the order given. In some cases where only partial testing is required, some steps can be eliminated. A complete test is not always required after repair of an individual section in the 650A. If, for example, only the output amplifier has been repaired, those steps pertaining to adjustment and calibration of the two oscillators should be omitted.

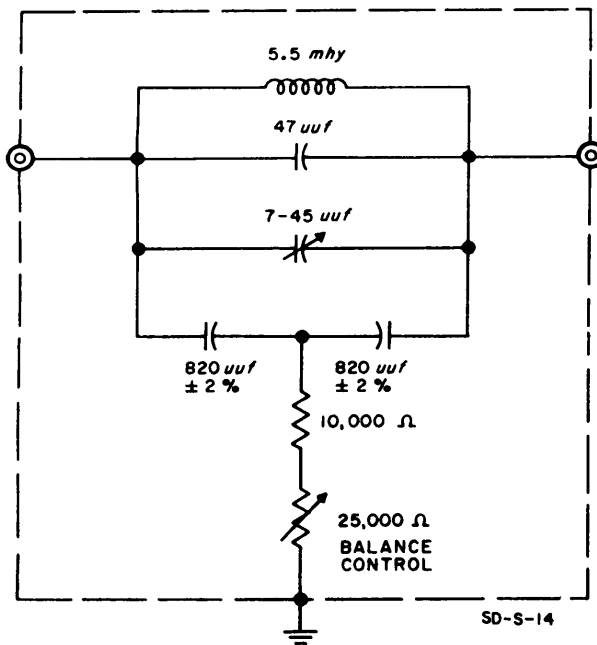

Figure 4-2. 100 kc Filter

00184-3

1) HEATER AND REGULATED POWER SUPPLY VOLTAGES

Adjust heater voltage and output of regulated power supply as instructed in paragraph 4-5.

2) PRELIMINARY LOW FREQUENCY RESPONSE ADJUSTMENT

A. Place a 600 ohm resistive load across output terminals, set FREQUENCY dial to "1", switch to the "X1KC" range, and adjust AMPLITUDE control to any convenient reference level on an external vacuum tube voltmeter connected across output terminals. This external ac VTVM must have known frequency response characteristics and must be accurately calibrated.

B. Turn FREQUENCY dial to "10" without disturbing any other control settings. The reading obtained on the external meter should be the same as the reference reading established in step A. The output frequency should be 10 kc as indicated by range switch and FREQUENCY dial positions. Adjust trimmer capacitors C23 and C24 simultaneously to obtain a 10 kc output signal having an amplitude equal to the reference level of step A.

If both frequency and amplitude requirements cannot be obtained, adjust to secure the correct amplitude at a frequency as near to 10 kc as possible. Final frequency calibration will be completed in a later step.

c. Repeat steps A and B.

3) LOW FREQUENCY OSCILLATOR OUTPUT VOLTAGE

Measure ac voltage at junction of R47, R54, and C28 with 650A tuned to 1000 cps. This oscillator voltage should be between 18 and 22 volts with approximately 19 volts being optimum in most instruments.

Large deviations from this voltage can be corrected by installing a new lamp for R80. Small deviations can be corrected by adjusting control R46.

If recovery time (indicated by low frequency flutter in output signal amplitude) is excessively long when switching ranges, slightly increase low frequency oscillator output by adjusting R46. If trouble persists, replace oscillator tubes V11 and/or V12.

4) LOW FREQUENCY OSCILLATOR DISTORTION

Low frequency oscillator distortion measured at junction of R47, R54, and C28 with instrument tuned to 1000 cps will normally be from 0.3% to 0.5%.

This exact figure is not critical as long as the distortion measured at the instrument output terminals does not exceed 1.0%.

Correct for excessive low frequency oscillator distortion by lowering the oscillator voltage or by replacing tubes V11 and/or V12.

5) LOW FREQUENCY OUTPUT DISTORTION

Measure distortion at 30, 1000, and 15,000 cps with distortion analyzer and a 600 ohm resistive load connected to output terminals. Distortion can be measured at 100 kc by means of an elimination filter as instructed under High Frequency Distortion.

Distortion in instrument output signal when tuned at any point between 10 cps and 100 kc should not exceed 1.0%.

6) CALIBRATION OF LOW FREQUENCY OSCILLATOR

Suggested setups for low frequency oscillator calibration and response checks are given in Figure 4-3. Any high impedance ac voltmeter capable of accurate voltage measurement from 10 cps to 100 kc can be used.

A. Connect a 600 ohm resistive load and frequency measuring equipment to 650A output terminals. See Figure 4-3.

B. Switch to the "X1KC" range and set FREQUENCY dial to "10" which provides an output signal of 10 kc.

C. Adjust frequency calibration at this dial point by adjusting trimmer capacitors C23 and C24. The output amplitude may be disregarded at this time.

D. Set FREQUENCY dial to "5" and measure output frequency which should be 5 kc. If frequency is off, remove knob directly under dial window and loosen, but do not remove four exposed Allen screws that secure dial to hub.

E. Set 650A for a 5 kc output signal. Slip frequency dial on hub to obtain a dial reading of "5" and retighten Allen screws.

F. Repeat steps B, C, D, and E.

G. Check dial calibration with dial set to "1" and other points between "1" and "10". If output frequency is not 1 kc with dial setting of "1", it may be necessary to change value of 1/2 watt padding resistors in series with R9 and/or R12. (See

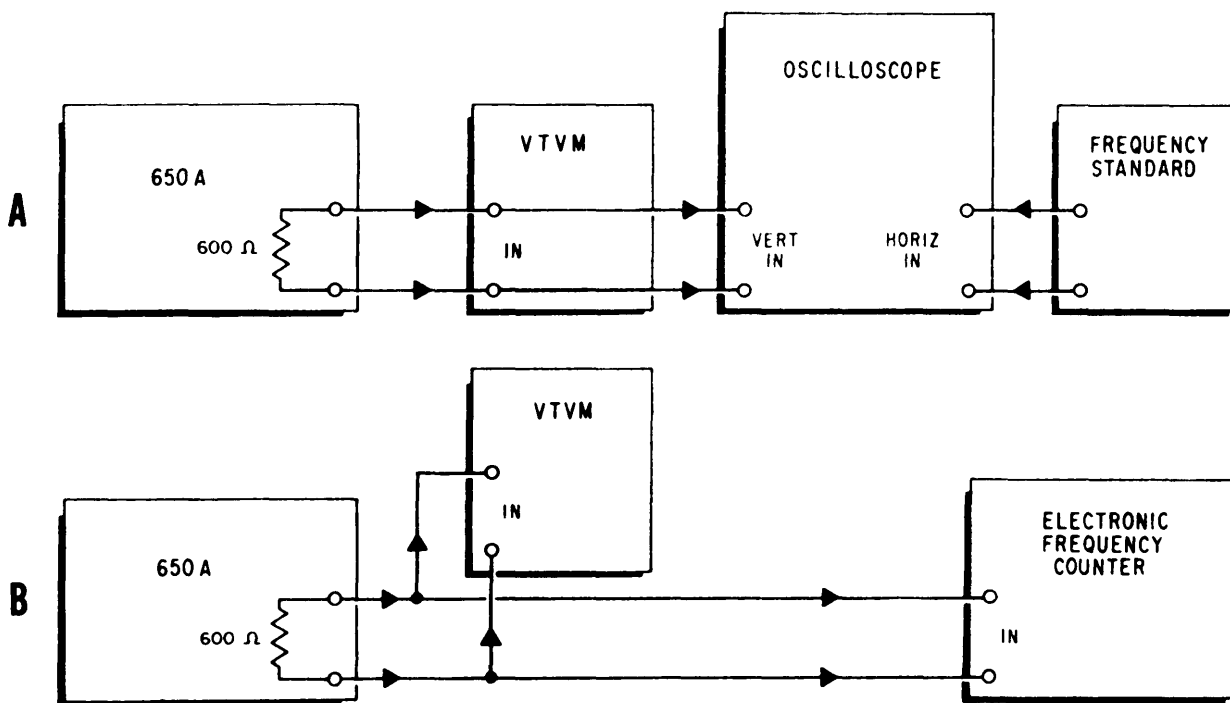

Figure 4-3. Calibration and Response Check for Low Frequency Oscillator (Figure B is suitable over entire 650A frequency range.)

CAUTION that follows.) If calibration error is not more than 2%, change either resistor value. If error is more than 2%, change both values an equal amount as an unbalanced condition will cause the oscillator to operate at a different level than the other ranges. Increasing resistor values will decrease oscillator frequency with any given tuning capacitor setting.

CAUTION

Before changing any 1/2 watt padding resistors, check the other low frequency oscillator ranges (X10 ν , X100 ν , and X10KC) for a possible constant error on all ranges. If error is constant, changing padding resistors for the X1K range would not be advisable.

H. Repeat step B then turn frequency dial to "8" and measure output frequency.

I. If output frequency is lower than 8 kc, bend end rotor plates outward on all sections of low frequency oscillator tuning capacitor. Bend only those segments of the rotor plates that are just meshing. If output frequency is high, bend rotor plates inward. Rotor and stator plates must not touch. Try to bend plates equally on all sections of the tuning gang.

J. Repeat step I at frequency dial setting of "5", "3", "2", "1.3", and "1". Adjust plate segments without changing those that have already been adjusted. Bring calibration to within approximately 1%.

K. Check frequency calibration of remaining low frequency oscillator ranges. These ranges should be within 1% calibration specifications. If they are not, change padding resistors for range that is off frequency as described in step G.

L. Calibration at 100 kc with range switch on "X10KC1" and FREQUENCY dial at "10" can be set by adjusting capacitor C25 in the cathode circuit of V11, the low frequency oscillator tube.

7) LOW FREQUENCY OSCILLATOR RESPONSE

A. Connect voltmeter and frequency measuring equipment as shown in Figure 4-3.

B. Repeat Preliminary Low Frequency Response Adjustment.

C. Check frequency response on three remaining low frequency oscillator ranges. Specifications require a response that is flat within ± 1 db from 10 cps to 100 kc with a 1 kc zero db reference. Adjacent ranges should be within 1/2 db of each other.

D. Repeat Low Frequency Output Distortion measurement.

8) OUTPUT METER FREQUENCY RESPONSE ADJUSTMENT

A. Connect a resistive load of 600 ohms across output terminals along with a high impedance ac meter of known accuracy up to 10 mc.

B. Adjust for a 1 mc output signal by switching to "X1M" range and setting FREQUENCY dial to "1".

C. Adjust AMPLITUDE control for a reference reading on both internal and external voltmeters and then turn FREQUENCY dial to "10".

D. Adjust AMPLITUDE control to obtain same reference reading on external voltmeter established in step C.

E. Adjust capacitor C42 in V16 cathode circuit to obtain same reference reading on internal voltmeter established in step C.

9) HIGH FREQUENCY RESPONSE ADJUSTMENT

A. Connect a resistive load of 600 ohms across the output terminals.

B. Turn H.F. Amplitude Adjust control (R25) maximum counterclockwise. Adjust C38 for minimum capacitance.

C. Set frequency range switch (S1) to "X1M" and frequency dial on "10" to provide a 10 mc output signal.

D. Adjust AMPLITUDE control (R55) to obtain 0 dbm indication on the internal voltmeter.

E. Set frequency dial on ".9" and adjust R25 to obtain 0 dbm indication on the internal voltmeter.

F. Set frequency dial on "10" and adjust C38 to obtain 0 dbm indication on the internal voltmeter:

G. Check overall frequency response of instrument from 10 cps to 10 mc. If necessary, repeat steps A through F (above). If the response is greater than ± 1 db (zero db reference point is at 1000 cps on the "X1KC" range) after completion of above adjustment, change the value of R90 in the plate circuit of V5 and repeat the procedure described above.

10) HIGH FREQUENCY DISTORTION MEASUREMENT

- A. Connect a resistive load of 600 ohms across output terminals.
- B. Adjust for a 100 kc output signal by switching to the "X100KC" range and setting FREQUENCY dial to "1".
- C. Adjust AMPLITUDE control to set output level to 3 volts as read by 650A output meter.
- D. Connect 100 kc filter shown in Figure 4-2 across output terminals and an external ac meter across filter output terminals. The meter used must be capable of accurately measuring frequencies that are harmonics of 100 kc. See block diagram given in Figure 4-4.
- E. Adjust balance control in filter and tune 650A to produce a minimum reading on external VTVM. The external meter reading should be 0.15 volt or less if instrument is within specifications of not more than 5% distortion at 100 kc.
- F. Distortion can be checked at higher frequencies if the necessary elimination filters are available.
- G. If distortion is excessive, interchange oscillator tubes V1, V2, and V3 or change buffer amplifier tube V4.
- H. If an Φ Model 3400A or 410C was used as the external meter during High Frequency Oscillator Response Adjustment, it will be necessary to go back and repeat this adjustment if the distortion was found to be excessively high in steps E and/or F above.

11) CHECK FM AT 10 MC

- A. Tune instrument to approximately 10 mc and connect a 10 mc crystal calibrator to output terminals. Set 650A output attenuator to "0.3 R.M.S. VOLTS" position.
- B. Monitor resultant beat note with a set of headphones. Zero beat should be indicated by a distinct null. A warbling beat note or lack of a distinct null would indicate fm in the output signal.
- C. RETURN OUTPUT ATTENUATOR TO "3.0 R. M. S. VOLTS" POSITION.

12) CALIBRATION OF HIGH FREQUENCY OSCILLATOR

- A. Connect frequency measuring equipment to 650A output terminals. See Figure 4-3A.
- B. Turn FREQUENCY dial to "10" and switch to the "X1M" range.
- C. Set output frequency to 10 mc by adjusting the three trimmer capacitors on top of left-hand tuning capacitor when viewing instrument from front. Any one or all three capacitors may be adjusted. However, adjustment of all three an equal amount is recommended.
- D. Check calibration at 5 mc. Correct by loosening Allen setscrews holding left-hand tuning capacitor shaft coupling and rotating capacitor shaft with respect to drive mechanism to obtain an output frequency of 5 mc with a dial reading of "5". Retighten setscrews.
- NOTE: Do not disturb relationship of right-hand, four section, turning gang and main frequency dial.
- E. Repeat step C.

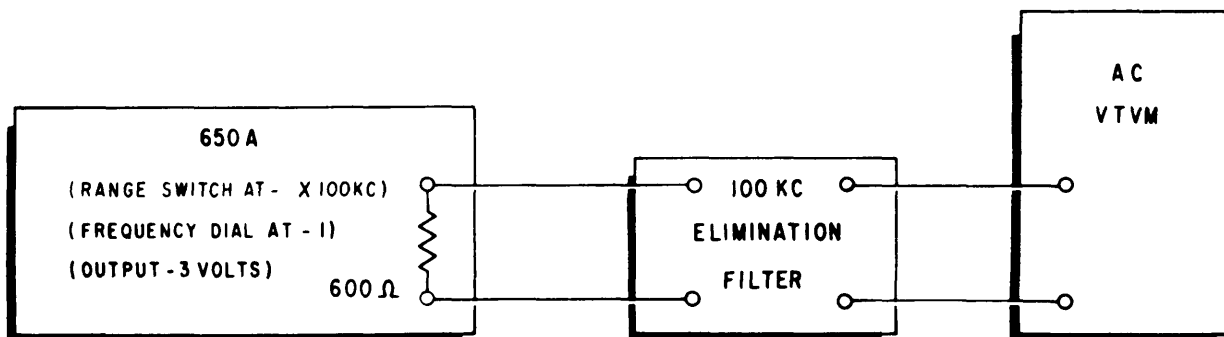

BD-S-29

Figure 4-4. Equipment for High Frequency Distortion Measurement

- F. Recheck 10 mc calibrations in step C.
- G. Slight tracking errors can be corrected by bending plates of the three section tuning capacitor for the high frequency oscillator. The technique for bending capacitor plates has already been discussed under Calibration of Low Frequency Oscillator (see step 6).

13) CALIBRATION OF X100KC RANGE

- A. Turn range switch to "X100KC" and set FREQUENCY dial to "10" which should provide an output frequency of 1 mc.
- B. Connect frequency determining equipment to output terminals. See Figure 4-3B.
- C. If measured output frequency is not 1 mc, adjust capacitor C3 (20-50 pf, ceramic) to obtain this frequency. This capacitor is mounted on the bottom side of mounting board for V1, V2, and V3.
- D. Adjust calibration at bottom (100 kc) of same range, if necessary, by changing padding resistors which are in series with R1, R2, and R5. These resistors are located on the range switch mounted below mounting board for tubes V1, V2, and V3. Any one or all three resistor values can be changed. However, an equal change for all three is recommended.
- E. If it was necessary to change padding resistors in step D, repeat adjustment of capacitor C3 as in step C.

14) OTHER ADJUSTMENTS

- A. Balance oscillator output levels. See paragraph 4-5.
- B. Check overall frequency response of 650A output meter. Response should be within ± 1 db over instrument frequency range of 10 cps to 10 mc. Zero db reference at 1000 cps on "X1KC" range.

- C. Check output hum level. Refer to paragraph 4-5 for procedure.
- D. Adjust output meter sensitivity and check output attenuator as instructed in paragraph 4-5.
- E. Check for a 60 pcs beat. See paragraph 4-5.
- F. Make a final recheck of frequency calibration on all six ranges. Make any adjustments found to be necessary.
- G. Check instrument response to line voltage change. See paragraph 4-5.
- H. Check output impedance and maximum output voltage. See paragraph 4-5.

4-7 TROUBLE SHOOTING

Notes given in Table 4-2 are based on Hewlett-Packard experience. The more common troubles, their symptoms, and remedy are given.

It is beyond the scope of this manual to include all possible or obscure and rare troubles. If an instrument develops trouble symptoms not covered by this table, repair analysis will be simplified if the Circuit Description given in this manual is used to obtain a complete understanding of the instrument circuitry. In case of persistent trouble, contact your Hewlett-Packard sales and service office.

All circuit references refer to Figures 4-10 and 4-11 unless otherwise noted. Signal, ac, or dc voltages when mentioned here, are measured between the indicated points and the chassis unless specified otherwise.

Tubes with standard EIA characteristics can be used for tube replacements as explained in paragraph 4-4. In a great number of cases, instrument trouble can be traced to a defective tube. Avoid transposing tubes of the same type in their respective sockets as this may disturb instrument adjustment.

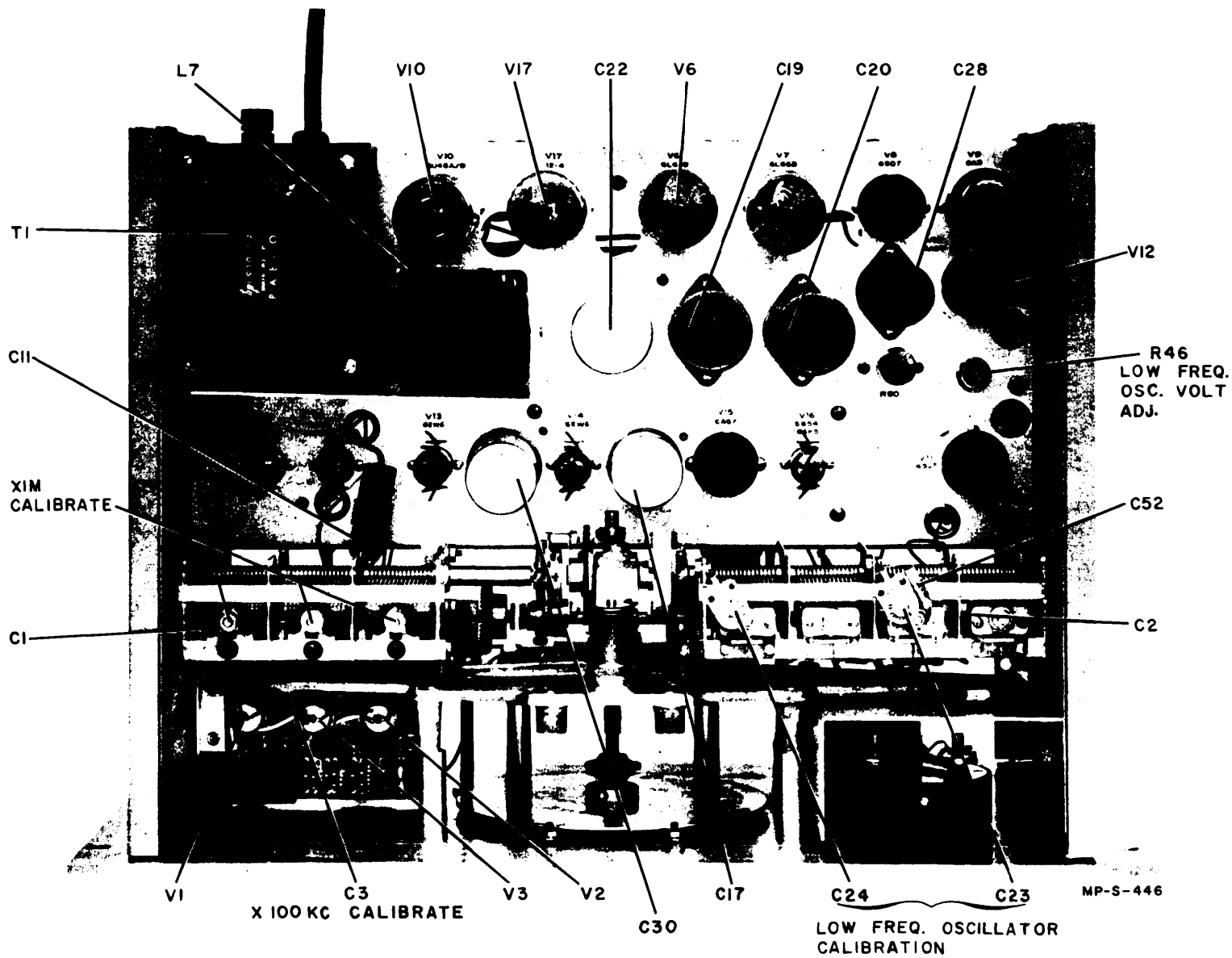

Figure 4-5. Model 650A Top View

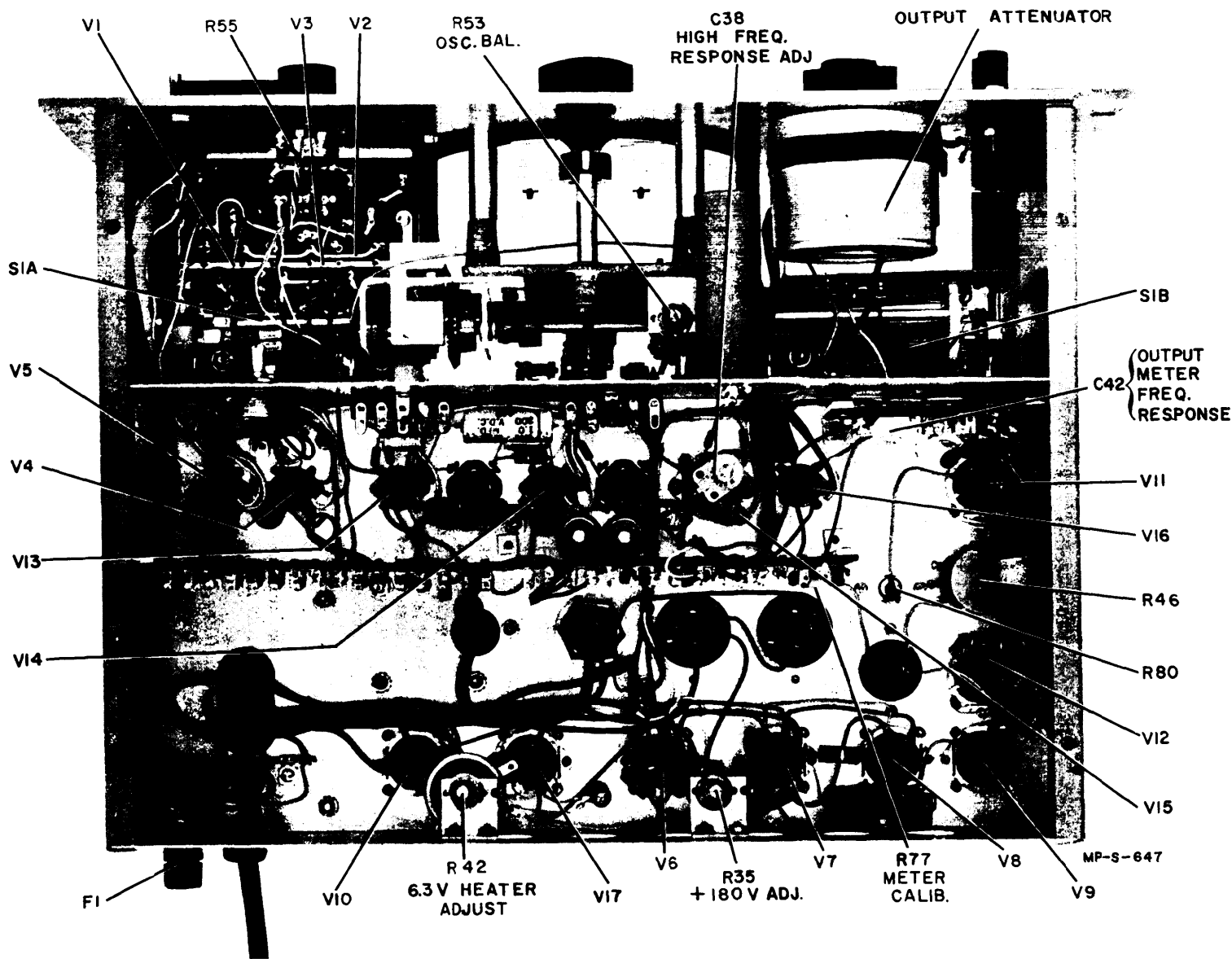

Figure 4-6. Model 650A Bottom View

TABLE 4-2. TROUBLE SHOOTING (Sheet 1 of 2)

Symptom	Cause and/or Remedy	Symptom	Cause and/or Remedy
Dead on all ranges.	Blown line fuse. Tube V13, V14, or V15 defective. Rectifier V10 defective. No B+ voltage.	Beat frequency at 60% ν .	Instrument bottom plate or top cover missing. Line frequency coupling to low frequency oscillator. Check dress of heater and dial light leads. Move leads away from tuning gangs and range switches. Heater-cathode leakage in V11, V12, V13, V14, and/or V 15.
No B+ voltage or Low B + voltage.	Rectifier V10 defective. Tubes V6 and/or V7 defective. Tube V8 shorted. Choke L7 open. Resistor R37 open. Defective filter capacitor. R34 open.	Motorboating or parasitic oscillation.	Regulator tube V9 defective. Tubes V12 or V15 defective. Regulated power supply not regulating. Control R55 is wirewound.
High B+ voltage. Cannot be adjusted by R35 control.	Tubes V6 or V7 shorted. Tubes V8 or V9 defective. Resistor R36 open.	Intermittent or noisy output particularly during frequency adjustment.	Tuning gangs are dirty or intermittently shorting.
Instrument blows line fuses.	Shorted rectifier V10. Shorted filter capacitor. Choke L7 shorted to chassis. Defective power transformer. Shorted heater wiring.	Fuzzy output pattern.	Heater - cathode leakage in V1, V2, V3, V11, or V12 will cause fm in output. Heater lead too close to range switch.
Power supply will not regulate with varying line voltage.	Defective tube in regulated power supply. Excessive power supply load due to failure elsewhere in instrument. Regulated output voltage set too high. Low dc input to regulator circuit.	Distortion and/or low output on all ranges.	B+ voltage not correct. Coil L5 open. Tubes V13, V14, and/or V15 defective. Defective coupling capacitor in output amplifier stages.
120 ν hum in instrument output.	Voltage regulator in power supply not regulating. Defective filter capacitors. Capacitor C18 defective.	Dead on two high ranges with no output meter indication on any range.	No regulated heater voltage for V1, V2, V3, V5, and V16 tubes. Ballast tube V17 defective or open power transformer winding.
60 ν hum in instrument output.	Heater-cathode leakage in any oscillator or amplifier tube. Capacitor C18 defective. Heater-cathode leakage in V6, V7, or V8.	Output meter reads low and cannot be corrected by R77 adjustment. Output meter has poor frequency response.	Tube V16 defective. Diodes CR1 or CR2 defective Defective meter movement. Capacitor C40 defective.

TABLE 4-2. TROUBLE SHOOTING (Sheet 2 of 2)

Symptom	Cause and/or Remedy	Symptom	Cause and/or Remedy
Residual output meter indication.	C43 or C44 capacitor defective. Tube V16 defective. Control R55 defective. Hum in output amplifier stages.	Poor frequency response at 10 cps.	Capacitors C28, C30, and/or C39 defective. Coupling capacitors C33 and/or C37 defective. Tubes V13, V14, V15, and/or V16 defective.
Microphonics.	Power supply series regulator tubes V6 and V7 defective. Dirt in tuning capacitor(s). Microphonics oscillator tube. Poor ground connection somewhere in instrument. Lamp R80 defective.	No high frequency oscillator output.	Shorted tuning gang or trimmers. Tubes V1, V2, V3, and/or V4 defective. Defective range switch. Capacitors C10, C48, and/or C50 defective. Ballast tube V17 defective.
Low frequency oscillator level cannot be set by R46 control.	Lamp R80 defective. Tube V11 or V12 defective. It may be necessary to correct frequency response by adjusting C23 and C24 capacitors. Add potentiometer for R46.	Low high frequency oscillator output.	Tube V5 defective. Low heater voltage. Resistor R25 defective. Tubes V1, V2, V3, and/or V4 weak.
Lamp R80 flashing.	Capacitors C2A, C23, and/or C52 shorted.	High frequency oscillator output too high.	Tube V5 defective. Diode CR3 defective. Capacitor C14 defective. Capacitors C12, C13, or C16 shorted. Coil L1 or resistor R25 open.
Low frequency oscillator distortion	Tube V11 and/or V12 defective. Low frequency oscillator output voltage set too high. Defective coupling capacitor. Tube V5 gassy.	Distortion and fm in high frequency oscillator.	V1, V2, V3 and/or V4 defective.
Output level on four lower ranges cannot be set to match two high frequency ranges by control R53.	High frequency oscillator output level too high or too low. Control R46 out of adjustment. Tube V5 defective.	Poor high frequency response.	V1, V2, V3, V4, and/or V5 defective. Diode CR3 defective. Tubes V13, V14, and/or V15 defective. Coil L5, and/or L8 defective.
		High frequency oscillator will not calibrates properly.	V1, V2, and/or V3 - C4, C6, and/or C9 defective
		No output on "X100KC" range only.	V1, V2, and/or V3 weak Defective range switch. Capacitor C3 shorted. R89 or R91 defective.
		Output frequency changes on two high ranges when R55 is adjusted.	Tube V4 defective.

4-8 DRIVE CABLE REPLACEMENT PROCEDURE

Two drive cables, one 11 inches and the other 15 inches (length before end loops are formed) will be required to replace the drive cables. These two cables are available from Hewlett-Packard, under stock number 816-3-650A.

- a. Remove old dial cable and screws at A, B, C, and D (see Figure 4-8). Loosen setscrew in spring loading collar on rear of drive shaft.
- b. Insert free end of 11-inch cable through hole A of drive pulley and form loop in end of cable as directed in Figure 4-7.
- c. Set instrument tuning dial to high frequency limit and rotate tuning capacitors so plates are open full. Fasten cable at A and thread as shown in Figure 4-8 with other end fastened by screw at B on large drum.
- d. Repeat steps b and c using the 15-inch cable. Start at C and finish at D on the small drum as shown in Figure 4-7.
- e. Revolve spring loading collar counterclockwise (viewed as shown in Figure 4-8) until slack is removed from drive cables. Rotate an additional half turn counterclockwise to tighten spring and tighten setscrew.
- f. Position cable on large drum so that first turn from drive pulley goes around large drum in a plane perpendicular to the axis of the drum and tangent to the outside of the drive pulley. Cable between idler pulley and small drum should be positioned so that it does not rub in notch in the vertical center post.
- g. Rotate tuning dial from one stop to the other for approximately 100 complete cycles to work out any stretch and allow cables to position themselves on the drums. Rotors of tuning capacitor sections should not be at the limit of their travel at either end of tuning range.
- h. Check dial calibration. If a constant error appears, loosen setscrew in drive pulley and rotate pulley slightly as required to correct this error.

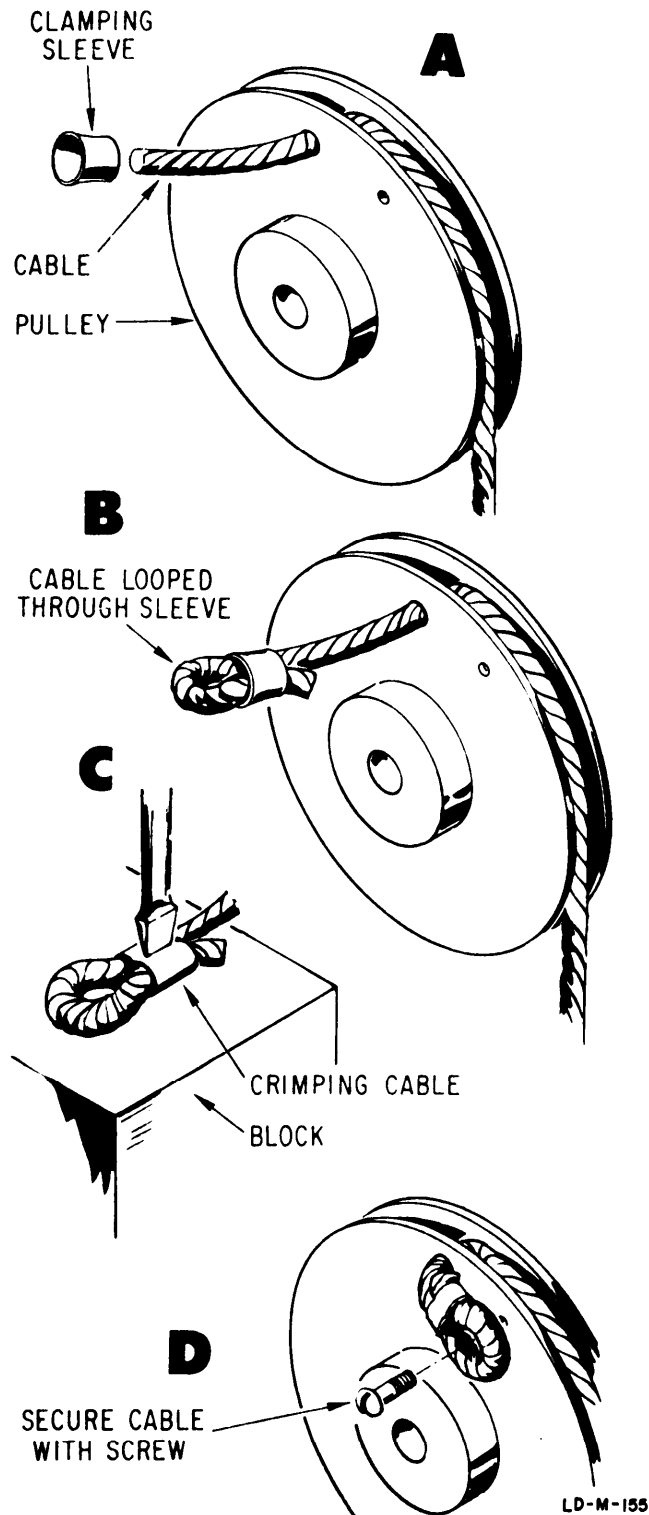

Figure 4-7. Installation of Eyelets on Plastic Coated Cable

INSTALLATION OF CLAMPING EYELETS ON ENDS OF PLASTIC COATED CABLE

The replacement cables are supplied from the factory with a loop formed in one end. The other end is not looped since it is necessary to thread this end through a hole in the pulley before the loop is formed. (See A of Figure 4-7.)

After passing open end of cable through hole in pulley, form a loop on the end of the cable the same size as the factory made loop on the opposite end of the cable. Slide eyelet over loop and tap with a plastic headed hammer until eyelet is flat. Size of loop and length of end protruding from eyelet should be the same as the other end of the cable.

Crimp center of eyelet as shown in C of Figure 4-7 with a screwdriver and a hammer.

Cable is now ready to be attached to the pulley using the small screw previously removed. (Refer to D of Figure 4-7.)

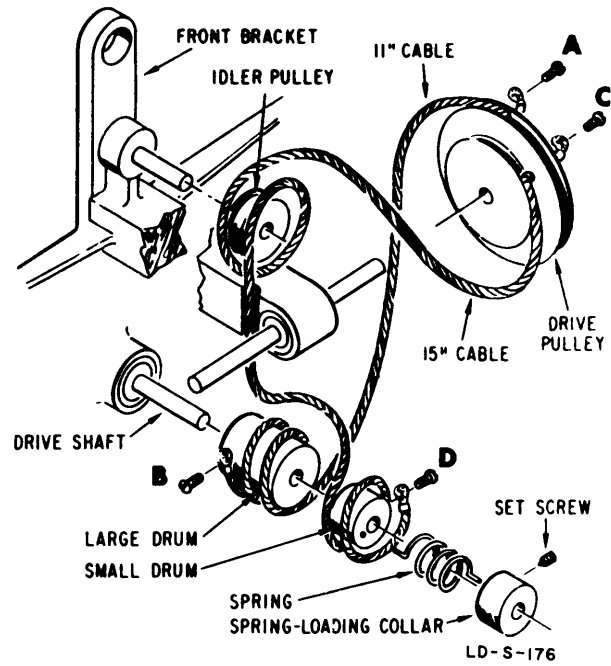

Figure 4-8. Exploded Rear View of Drive Cabling

SERVICING ETCHED CIRCUIT BOARDS

Excessive heat or pressure can lift the copper strip from the board. Avoid damage by using a low power soldering iron (50 watts maximum) and following these instructions. Copper that lifts off the board should be cemented in place with a quick drying acetate base cement having good electrical insulating properties.

A break in the copper should be repaired by soldering a short length of tinned copper wire across the break.

Use only high quality rosin core solder when repairing etched circuit boards. NEVER USE PASTE FLUX. After soldering, clean off any excess flux and coat the repaired area with a high quality electrical varnish or lacquer.

When replacing components with multiple mounting pins such as tube sockets, electrolytic capacitors, and potentiometers, it will be necessary to lift each pin slightly, working around the components several times until it is free.

WARNING: If the specific instructions outlined in the steps below regarding etched circuit boards without eyelets are not followed, extensive damage to the etched circuit board will result.

1. Apply heat sparingly to lead of component to be replaced. If lead of component passes through an eyelet in the circuit board, apply heat on component side of board. If

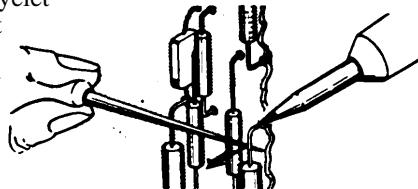

component does not pass through an eyelet, apply heat to conductor side of board.

2. Reheat solder in vacant eyelet and quickly insert a small awl to clean inside of hole. If hole does not have an eyelet, insert awl or a #57 drill from conductor side of board.

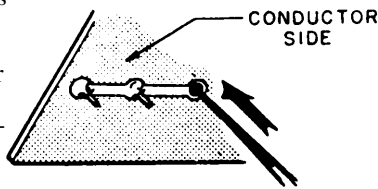

3. Bend clean tinned lead on new part and carefully insert through eyelets or holes in board.

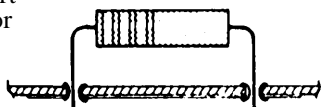

4. Hold part against board (avoid overheating) and solder leads. Apply heat to component leads on correct side of board as explained in step 1.

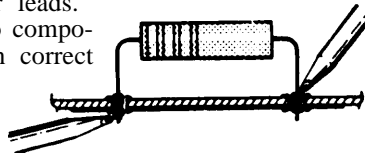

In the event that either the circuit board has been damaged or the conventional method is impractical, use method shown below. This is especially applicable for circuit boards without eyelets.

1. Clip lead as shown below.

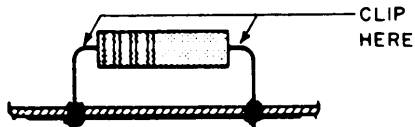

2. Bend protruding leads upward. Bend lead of new component around protruding lead. Apply solder using a pair of long nose pliers as a heat sink.

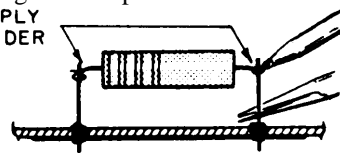

This procedure is used in the field only as an alternate means of repair. It is not used within the factory.

Figure 4-9. Servicing Etched Circuit Boards

00184-2

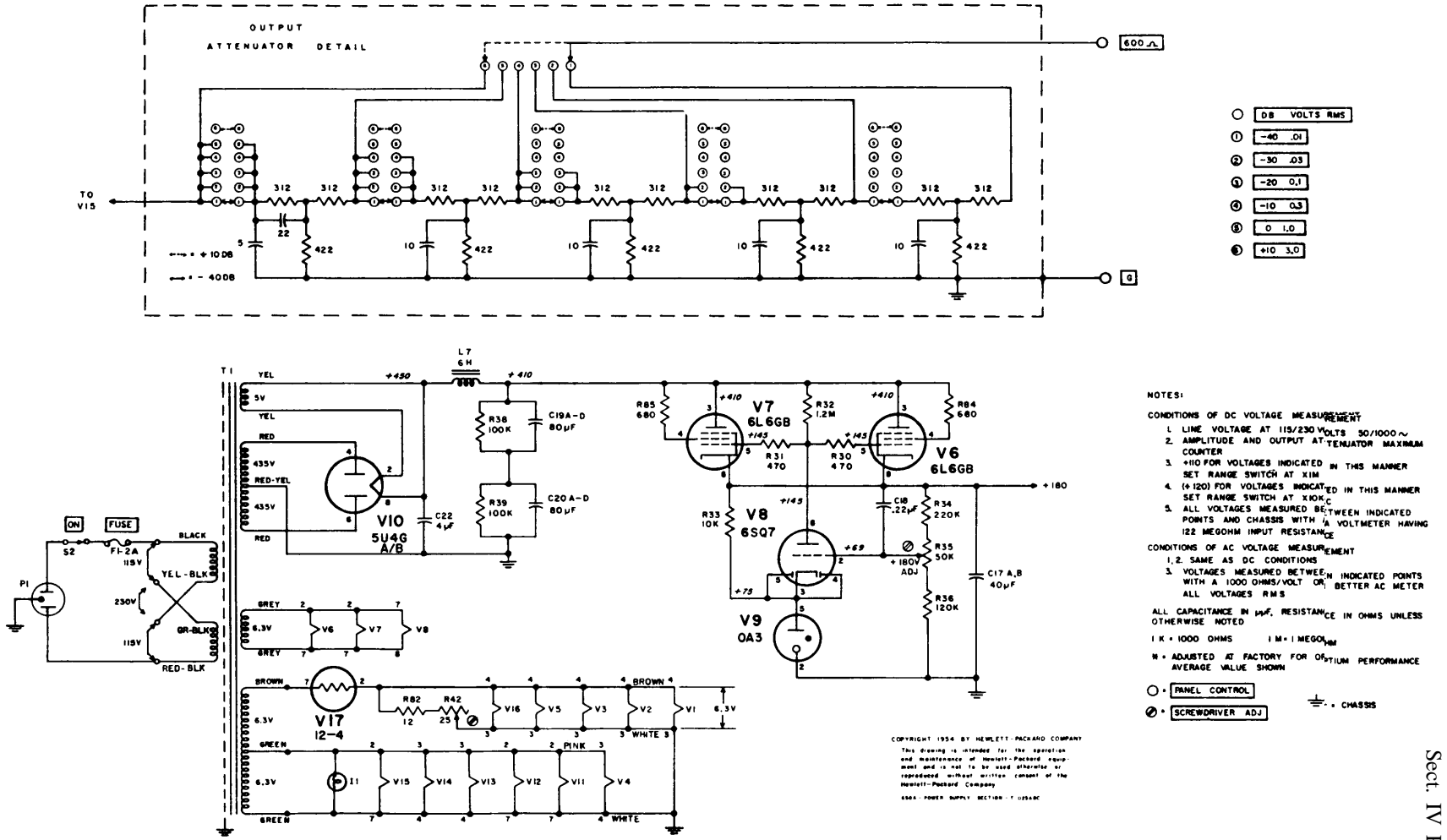
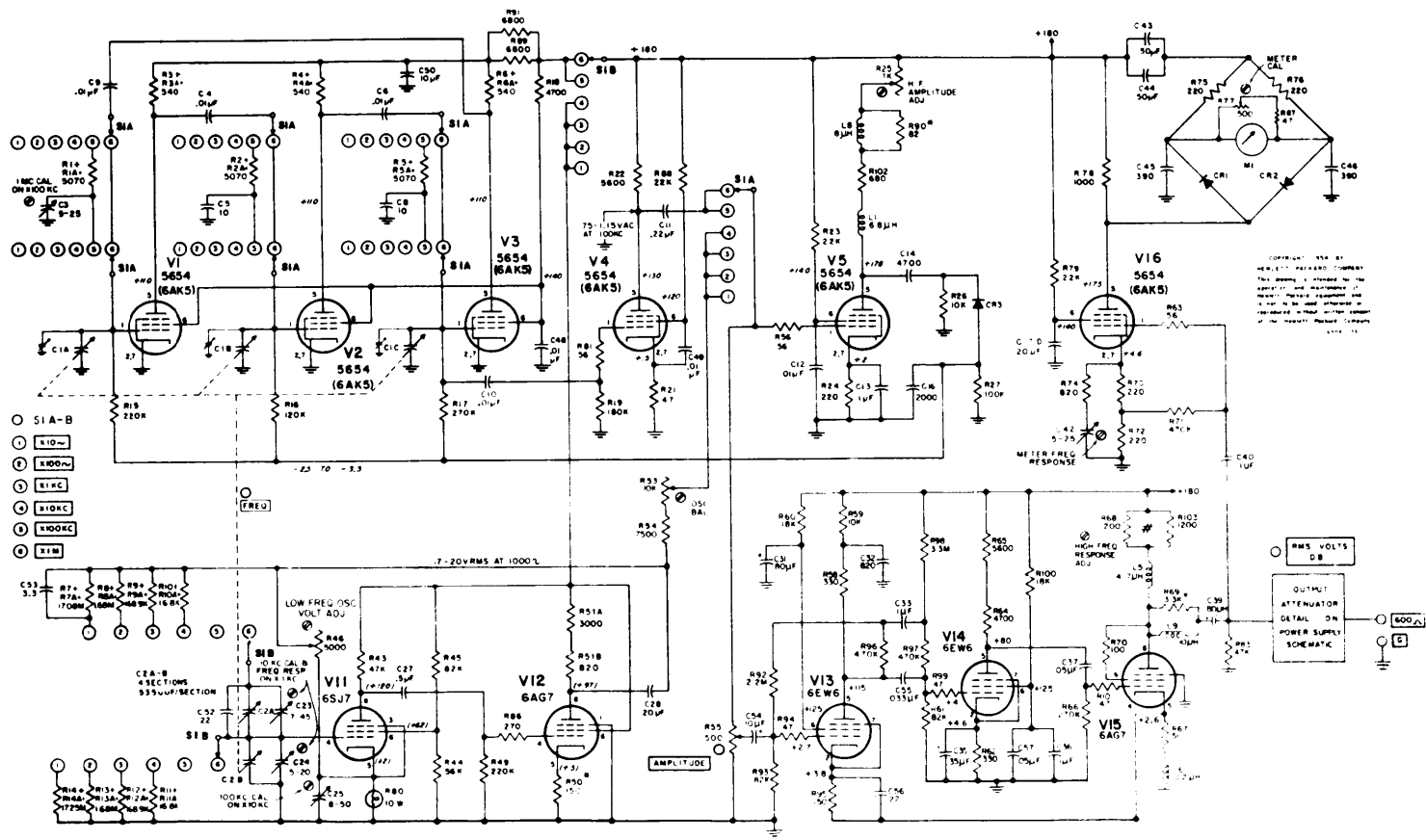

Figure 4-10. Power Supply Section



00184-4

Section V. PREVENTIVE MAINTENANCE SERVICES

5-1. Scope of Maintenance

The maintenance duties assigned to the operator of the AN/USM-205 are listed below together with a reference to the paragraphs covering the specific maintenance function. The duties assigned do not require tools or test equipment other than those issued with the signal generator.

- a. Daily preventive maintenance checks and services (para 5-4).
- b. Weekly preventive maintenance checks and services (para 5-5).
- c. Cleaning (para 5-6).
- d. Monthly preventive maintenance checks and services (para 5-8).
- e. Touchup painting (para 5-9).

5-2. Preventive Maintenance

Preventive maintenance is the systematic care, servicing, and inspection of equipment to prevent the occurrence of trouble, to reduce downtime, and to assure that the equipment is serviceable.

a. Systematic Care. The procedures given in paragraphs 5-4 through 5-8 cover routine systematic care and cleaning essential to proper upkeep and operation of the equipment.

b. Preventive Maintenance Checks and Services. The preventive maintenance checks and services charts outline functions to be performed at specific intervals. These checks and services are to maintain Army electronic equipment in a combat serviceable condition; that is, in good general (physical) condition and in good operating condition. To assist operators in maintaining combat serviceability, the charts indicate what to check, how to check, and what the normal conditions are. The References column lists the illustrations, paragraphs, or manuals that contain detailed repair or replacement procedures. If the defect cannot be remedied by the operator, higher echelon maintenance or repair is required. Records and reports of these checks and services must be made in accordance with the requirements set forth in TM 38-750.

5-3. Preventive Maintenance Checks and Services Periods

Preventive maintenance checks and services are required daily, weekly, and monthly. Paragraphs 5-3, 5-4, and 5-8 specify the items to be checked and serviced. In addition to the routine daily, weekly, and monthly checks and services, the equipment should be rechecked and serviced immediately before going on a mission and as soon after completion of the mission as possible.

5-4. Daily Preventive Maintenance Checks and Services Chart

Sequence No.	Item	Procedure	References
1	Completeness	Be sure the equipment is complete, appx III.	
2	Cleaning	Remove dirt and moisture from exposed surfaces of the case and housing.	Para 2-6.
3	Meter window	Inspect the meter windows for broken glass.	
4	Pilot light	During operation (item 7 below), inspect for a burned-out pilot light.	
5	Meter movement	During operation (item 7 below), check for sticking meter movement.	
6	Knobs, dials, and switches.	While making the operating check (item 7 below), observe that the mechanical action of each knob, dial, and switch is smooth and free of external or internal binding.	
7	Operation	During operation, be alert for any unusual performance or condition.	

5-5. Weekly Preventive Maintenance Checks and Services Chart

Sequence No.	Item	Procedure	References
1	Cords and cables	Inspect cords and cables for cuts, cracks, strain, fraying, or deterioration.	
2	Handle and latches	Hand-check for looseness of handle and latches.	
3	Preservation	Inspect exposed metal surfaces for rust and corrosion. If present, refer to paragraph 5-9.	

5-6. Cleaning

Inspect the exterior of the signal generator. The exterior surfaces should be free of dust, dirt, grease, and fungus.

a. Remove dust and loose dirt with a clean soft cloth.

Warning: Cleaning Compound is flammable and its fumes are toxic. Provide adequate ventilation. Do not use near a flame.

b. Remove grease, fungus, and ground-in dirt from the cases; use a cloth dampened (not wet) with Cleaning Compound (Federal stock No. 7930-395-9542).

c. Remove dust or dirt from plugs and jacks with a brush.

Caution: Do not press on the meter face (glass) when cleaning; the meter may be damaged.

d. Clean the front panels, meters, and control knobs; use a soft clean cloth. If dirt is difficult to remove dampen the cloth with water; mild soap may be used for more effective cleaning.

5-7. Monthly Maintenance

Perform the maintenance functions indicated in the monthly preventive maintenance checks and services chart (para 5-8) once each month. A month is defined as approximately 30 calendar days of 8-hour-per-day operation. If the equipment is operated 16 hours a day, the monthly preventive maintenance checks and services should be performed at 15-day intervals. Adjustment of the maintenance interval must be made to compensate for any unusual operating conditions. Equipment maintained in a standby (ready for immediate operation) condition must have monthly preventive maintenance checks and services. Equipment in limited storage (requires service before operation) does not require monthly preventive maintenance.

5-8. Monthly Preventive Maintenance Checks and Services Chart

Sequence No.	Item	Procedure	References
1	Pluckout items	Inspect seating of readily accessible items of a pluckout nature such as fuses, connectors, tubes, and lamps. Do not remove, rock, or twist to inspect. Use only direct pressure to insure item is fully seated.	
2	Resistors and capacitors.	Inspect resistors and capacitors for cracks, blistering, or other detrimental defects.	
3	Publications	See that all publications are complete, serviceable, and current.	DA Pam 310-4.
4	Modifications	Check DA Pamphlet 310-4 to determine if new applicable MWO's have been published. All URGENT MWO's must be applied immediately. All NORMAL MWO's must be scheduled.	DA Pam 310-4 and TM 38-750.

5-9. Touchup Painting Instructions

Remove rust and corrosion from metal surfaces by lightly sanding them with fine sandpaper. Brush two thin coats of paint on the bare metal to protect it from further corrosion. Refer to the applicable cleaning and refinishing practices specified in TM 9-213.

Manual Changes Model 650A Page 2

Instrument	Serial Prefix	Make Manual Changes	Instrument	Serial Prefix	Make Manual Changes
203-		1			
150-		1, 2			
025-		1, 2, 3			

L9: delete
 R83: change description to read "Same as R43"

Change Schematic Figure 4-11 as shown below:

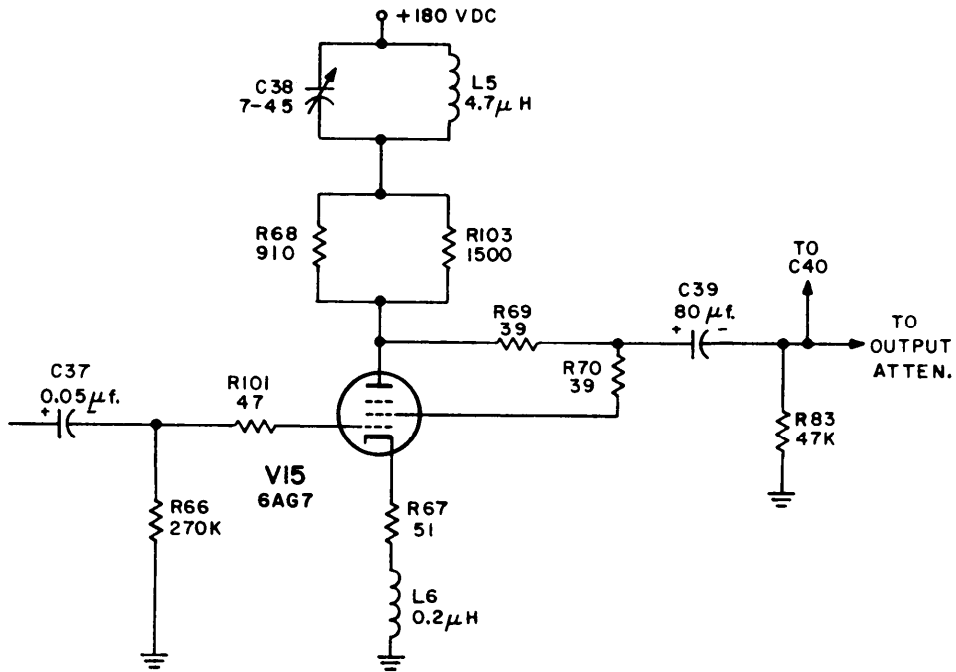

NOTES

APPENDIX III

MAINTENANCE ALLOCATION

Section I. INTRODUCTION

A3-1. General

a. This appendix assigns maintenance functions to be performed on components, assemblies, and subassemblies by the lowest appropriate maintenance category.

b. Columns in the maintenance allocation chart are as follows:

- (1) Part or component. This column shows only the nomenclature or standard item name. Additional descriptive data are included only where clarification is necessary to identify the component. Components, assemblies, and subassemblies are listed in top-down order. That is, the assemblies which are part of a component are listed immediately below that component, and subassemblies which are part of an assembly are listed immediately below that assembly. Each generation breakdown (components, assemblies, or subassemblies) are listed in disassembly order or alphabetical order.
- (2) Maintenance function. This column indicates the various maintenance functions allocated to the categories.
 - (a) Service. To clean, to preserve, and to replenish lubricants.
 - (b) Adjust. To regulate periodically to prevent malfunction.
 - (c) Inspect. To verify serviceability and detect incipient electrical or mechanical failure by scrutiny.
 - (d) Test. To verify serviceability and to detect incipient electrical or mechanical failure by use of special equipment such as gages, meters, etc.
 - (e) Replace. To substitute serviceable components, assemblies, or subassemblies, for unserviceable components, assemblies, or subassemblies.

- (f) Repair. To restore an item to serviceable condition through correction of a specific failure or unserviceable condition. This function includes but is not limited to welding, grinding, riveting, straightening, and replacement of parts other than the trial and error replacement of running spare type items such as fuses, lamps, or electron tubes.
- (g) Align. To adjust two or more components of an electrical system so that their functions are properly synchronized.
- (h) Calibrate. To determine, check, or rectify the graduation of an instrument, weapon, or weapons system, or components of a weapons system.
- (i) Overhaul. To restore an item to completely serviceable condition as prescribed by serviceability standards developed and published by heads of technical services. This is accomplished through employment of the technique of "Inspect and Repair Only as Necessary" (IROAN). Maximum utilization of diagnostic and test equipment is combined with minimum disassembly of the item during the overhaul process.
- (j) Rebuild. To restore an item to a standard as near as possible to original or new condition in appearance, performance, and life expectancy. This is accomplished through the maintenance technique of complete disassembly of the item, inspection of all parts or components, repair or replacement of worn or unserviceable elements using original manufacturing tolerances and/or specifications and subsequent reassembly of the item.
- (3) Operator, organization, direct support, general support, and depot. The symbol X indicates the categories responsible for performing that particular maintenance operation, but does not necessarily indicate that repair parts will be stocked at that level. Categories higher than those marked by X are authorized to perform the indicated operation.
- (4) Tools required. This column indicates codes assigned to each individual tool equipment, test equipment, and maintenance equipment referenced. The grouping of codes in this column of the maintenance allocation chart indicates the tool, test, and maintenance equipment required to perform the maintenance function.
- (5) Remarks. Entries in this column will be utilized when necessary to clarify any of the data cited in the preceding columns.

c. Columns in the allocation of tools for maintenance functions are as follows:

- (1) Tools required for maintenance functions. This column lists tools, test, and maintenance equipment required to perform the maintenance functions.

(2) Operator, organization, direct support, general support, and depot.
The dagger symbol indicates the categories normally allocated the facility.

(3) Tool code. This column lists the tool code assigned.

A3-2. Maintenance by Using Organizations

When this equipment is used by signal services organizations organic to theater headquarters or communication zones to provide theater communications, those maintenance functions allocated up to and including general support are authorized to the organization operating this equipment.

SECTION II. MAINTENANCE ALLOCATION CHART

PART OR COMPONENT	MAINTENANCE FUNCTION	MAINTENANCE CATEGORY					TOOLS REQUIRED	REMARKS
		O/C	O	DS	GS	D		
GENERATOR SIGNAL AN/USM-205	service	X					1,5,7,10	Preventive Maintenance Visual
	inspect	X						
	test			X			1,2,3,4,5,8,9,10,11, 12,13,14,15,16	
						X	1,2,3,4,5,6,8,9,10, 11,12,13,14,15,16	
	repair	X					10	Pluck out items, tubes, lamps, and fuses.
					X		10	
align				X		1,2,3,4,5,8,9,10,11, 12,13,14,15,16	Low frequency and high frequency oscillator. Depot facilities Shop	
calibrate				X		1,2,3,4,5,8,9,10,11, 12,13,14,15,16		
rebuild overhaul					X			

SECTION III. ALLOCATION OF TOOLS FOR MAINTENANCE FUNCTIONS

TOOLS REQUIRED FOR MAINTENANCE FUNCTIONS	MAINTENANCE CATEGORY					TOOL CODE	SERVICE	TYPE CLASS	REMARKS
	O/C	O	DS	GS	D				
AN/USM-205 (continued)									
OSCILLOSCOPE, AN/USM-81	+			+	+	1	ARMY	STD. A	See Note 1
MULTIMETER, ME-26B/U				+	+	2	ARMY	STD. A	See Note 1
MULTIMETER, ME-30/U				+	+	3	ARMY	STD. A	See Note 1
FREQUENCY METER, AN/USM-26				+	+	4	ARMY	STD. A	See Note 2
TEST SET, ELECTRON TUBE TV-7B/U	+			+		5	ARMY	STD. A	See Note 1
TEST SET, ELECTRON TUBE TV-2/U					+	6	ARMY	STD. A	See Note 1
MULTIMETER, AN/URM-105	+					7	ARMY	STD. A	See Note 1
MULTIMETER, TS-352B/U				+	+	8	ARMY	STD. A	See Note 1
ANALYZER SPECTRUM, TS-723A/U				+	+	9	ARMY	STD. A	See Note 2
TOOL KIT, ELECTRONIC EQUIPMENT REPAIR TK-105/G	+			+	+	10	ARMY	STD. A	See Note 1
COIL RADIO FREQUENCY: FSN-5950-143-8936				+	+	11	N/A	N/A	See Note 2
CAPACITOR FIXED, CERAMIC DIELECTRIC: FSN-5910-807-1543				+	+	12	N/A	N/A	See Note 2
CAPACITOR, VARIABLE, CERAMIC DIELECTRIC: FSN-5910-578-1623				+	+	13	N/A	N/A	See Note 2
CAPACITOR, FIXED, CERAMIC DIELECTRIC: FSN-5910-681-2491				+	+	14	N/A	N/A	See Note 2
RESISTOR, FIXED, COMPOSITION: FSN-5905-185-8510				+	+	15	N/A	N/A	See Note 2
RESISTOR, VARIABLE, COMPOSITION: FSN-5905-577-7337				+	+	16	N/A	N/A	See Note 2
NOTE 1: Available with AN/FPA-15 2: Not available with AN/FPA-15									

APPENDIX IV

ORGANIZATIONAL, DIRECT AND GENERAL SUPPORT, AND DEPOT REPAIR PARTS LIST

Section I. INTRODUCTION

A4-1. General

a. This appendix includes an organizational, direct and general support and depot maintenance special tools list.

- (1) The organizational Maintenance repair parts and special tools list lists the repair parts authorized for organizational maintenance and is a basis for requisitioning by organizations which are authorized the major item of equipment. End items of equipments are issued on the basis of allowances prescribed in equipment authorization tables and other documents that are a basis for requisitioning.
- (2) Direct and general support and depot maintenance repair parts and special tools list shows the quantities of repair parts authorized for general support maintenance and is a basis for requisitioning authorized parts. It is also a guide for depot maintenance in establishing initial levels of spare parts.

b. Columns are as follows:

- (1) Source, maintenance, and recoverability code. Source, maintenance, and recoverability codes indicate the technical service responsible for supply, the maintenance category at which an item is stocked, categories at which an item is installed or repaired, and whether an item is repairable or salvageable. The source code column is divided into four parts.
 - (a) Column A. This column indicates the materiel code and designates the area of responsibility for supply. AR 310-1 defines the basic numbers used to identify the materiel code. If the part is Signal materiel responsibility, the column is left blank.

(b) Column B. This column indicates the point within the maintenance system where the part is available. "P" indicates that the repair part is a high mortality part; procured by technical services, stocked in and supplied from the technical service depot system, and authorized for use at indicated maintenance categories. "P1" indicates that the repair part is a low mortality part; procured by technical services, stocked only in and supplied from technical service key depots, and authorized for installation at indicated maintenance categories.

(c) Column C. This column indicates the lowest maintenance categories authorized to install the part.

"O"- Organizational maintenance (operator and organizational).

"H" - General support maintenance.

(d) Column D. Not used.

- (2) Federal stock number. This column lists the 11-digit Federal stock number.
- (3) Designation by model. Not used.
- (4) Description. Nomenclature or the standard item name and brief identifying data for each item are listed in this column. When requisitioning, enter the nomenclature and description.
- (5) Unit of issue. The unit of issue is each unless otherwise indicated and is the supply term by which the individual item is counted for procurement, storage, requisitioning, allowances, and issue purposes.
- (6) Expendability. Nonexpendable items are indicated by NX. Expendable items are not annotated.
- (7) Quantity incorporated in unit. This column lists the quantity of each part found in a given assembly, component, or equipment.
- (8) Organizational. An asterisk (*) indicates that an item is not authorized for stockage but if required, may be requisitioned for immediate use only.
- (9) Direct support. No parts authorized for stockage.
- (10) General support. The numbers in this column indicate quantities of repair parts authorized for initial stockage for use in general support maintenance. The quantities are based on 100 equipments to be maintained for a 15-day period.

- (11) Depot. The numbers in this column indicate quantities of repair parts authorized for depot maintenance and for initial stockage for maintenance, and for supply support to lower categories. The entries are based on the quantity required for rebuild of 100 equipments.
- (12) Illustration. The "Item No." column lists the reference designations that appear on the part in the equipment. These same designations are also used on any illustrations of the equipment. The numbers in the "Figure No." column refer to the illustrations where the part is shown.

A4-2. Parts for Maintenance

When this equipment is used by signal service organizations organic to theater headquarters or communication zones to provide theater communications, those repair parts authorized up to and including general support are authorized for stockage by the organization operating this equipment.

A4-3. Electron Tubes

The consumption rates given for tubes are conservative theoretical estimates and are provided for use only when more complete information, such as data based on operating experience, is not available. These figures are based on levels and requirements for equipment actually in use, not on authorizations or equipment stored in depots.

A4-4. Requisitioning Information

a. The allowance factors are based on 100 equipments. In order to determine the number of parts authorized for initial stockage for the specific number of equipments supported, the following formula will be used and carried out to two decimal places.

$$\text{Specific number of equipments supported} \times \frac{\text{allowance factor}}{100} =$$

Number of parts authorized for initial stockage.

b. Fractional values obtained from above computation will be rounded to whole numbers as follows:

- (1) When the total number of parts authorized is less than 0.5, the quantity authorized will be zero.
- (2) When the total number of parts authorized is between 0.5 and 1.0, the quantity authorized will be one.

(3) For all values above one, fractional values below 0.5 will revert to the next lower whole number and fractional value 0.5 and above will advance to the next higher whole number.

c. The quantities determined in accordance with the above computation represent the Initial stockage for a 15-day period.

SECTION II. ORGANIZATIONAL FUNCTIONAL PARTS LIST

FEDERAL STOCK NUMBER	DESIGNATION BY MODEL	DESCRIPTION	UNIT OF ISSUE	EXP	QTY IN UNIT	ORGANIZATIONAL	ILLUSTRATION	
							FIGURE NO.	ITEM NO.
6625-788-9672		GENERATOR, SIGNAL AN/USM-205		NX				
5995-985-8214		CABLE ASSEMBLY, RADIO FREQUENCY: CG-2733/U, (4 ft 0 in)			1	*		
6625-759-7436		DIVIDER, VOLTAGE: MX-6122/U			1	*	2-1	
5960-262-1357		ELECTRON TUBE: MIL type 5654/6AK5W			6	*	4-5	V1, V2, V3, V4, V5, V16
5960-834-3368		ELECTRON TUBE: EIA type p/n 6L6GC			2	*	4-5	V6, V7
5960-100-5273		ELECTRON TUBE: EIA type p/n 6SQ7			1	*	4-5	V8
5960-557-6929		ELECTRON TUBE: EIA type p/n 0A3			1	*	4-5	V9
5960-817-7100		ELECTRON TUBE: EIA type p/n 5U4GAB			1	*	4-5	V10
5960-100-5268		ELECTRON TUBE: MIL type 6SJ7Y			1	*	4-5	V11
5960-617-9075		ELECTRON TUBE: EIA type p/n 6AG7			2	*	4-5	V12, V15
		ELECTRON TUBE: EIA type p/n 6EW6; L4SA46-A153			2	*	4-5	V13, V14
5920-295-9074		FUSE, CARTRIDGE: 2 amps; 125 v maximum; Bussman Mfg Div. p/n MDL2			1	*	4-6	F1
6240-617-1488		LAMP INCANDESCENT: 6.3 v; 0.15 amps; bipin base; General Electric Co. lamp no. 12			1	*		DS1
6240-151-4914		LAMP, INCANDESCENT: 250 v; 10 w; General Electric Co. lamp no. 8A/S6-12V			1	*	4-6	DS2 or R80
6210-729-9081		LENS, INDICATOR LIGHT: Power ON-OFF; Drake Mfg Co. p/n 14L15			1	*		
		KNOB: Amplitude control; Hewlett-Packard Co. p/n 0370-0032; L4SA46-A012			1	*		
		KNOB: Tuning; Hewlett-Packard Co. p/n 0370-0038; L4SA46-A014			2	*		

ATV-6

FEDERAL STOCK NUMBER	DESIGNATION BY MODEL	DESCRIPTION	UNIT OF ISSUE	EXP	QTY IN UNIT	ORGANIZATIONAL	ILLUSTRATION	
							FIGURE NO.	ITEM NO.
5960-296-7505		AN/USM-205 (continued)						
		KNOB: Rms volts-db; frequency; Hewlett-Packard p/n 0370-0035; L4SA46-A013 RESISTOR, CURRENT REGULATING: Amperite Co. p/n 12-4						
					2	*		
					1	*	4-5	V17

SECTION III. GENERAL SUPPORT AND DEPOT FUNCTIONAL PARTS LIST

SOURCE CODE	FEDERAL STOCK NUMBER	DESIGNATION BY MODEL	DESCRIPTION	UNIT OF ISSUE	EXP	QTY IN UNIT	DIRECT SUPPORT	GENERAL SUPPORT	DEPOT	ILLUSTRATION	
										FIGURE NO.	ITEM NO.
A	B	C	D								
			GENERATOR, SIGNAL AN/USM-205								
	6625-788-9672		GENERATOR, SIGNAL AN/USM-205		NX						
Pl	H		6625-877-8170 AMMETER: dc type; Hewlett-Packard Co. p/n 1120-0014			1		0.2	3.0		M1
P	H		5905-677-4432 ATTENUATOR, VARIABLE: output control; Hewlett-Packard Co. p/n 65A-34			1		0.3	6.0	4-6	
P	H		3110-100-6149 BEARING, BALL: Hewlett-Packard Co. p/n 1410-0024			2		0.3	6.0		
Pl	H		5995-848-8057 CABLE ASSEMBLY, POWER: 7.5 ft lg o/a; Belden Mfg Co. p/n KH3981-PH70-7.5			1		0.3	7.0		
Pl	O		5995-985-8214 CABLE ASSEMBLY, RADIO FREQUENCY: CG-2733/U (4 ft 0 in).			1		0.3	5.0		
Pl	H		5910-874-6891 CAPACITOR, FIXED, CERAMIC DIELECTRIC: 10,000 pf ±20%; 1,000 wvdc; Sprague Electric Co. p/n 29C214A3			4		0.4	12.0		C10, C12, C48, C49
Pl	H		5910-851-7199 CAPACITOR, FIXED, CERAMIC DIELECTRIC: 2,000 pf ±20%; 1,000 wvdc; Sprague Electric Co. p/n 19C203A			1		0.2	3.0		C16
Pl	H		5910-797-4909 CAPACITOR, FIXED, CERAMIC DIELECTRIC: 50,000 pf ±20%; 400 wvdc; Sprague Electric Co. p/n 33C17A,			2		0.2	6.0		C37, C57
Pl	H		5910-805-2820 CAPACITOR, FIXED, CERAMIC DIELECTRIC: 22 pf ±5%; 500 wvdc; HI-Q Division of Aerovox Corp p/n C1-2-22PF-PORM5			1		0.2	3.0		C52
Pl	H		5910-819-8237 CAPACITOR, FIXED, ELECTROLYTIC: 4 sections; 20 uf each section; 450 wvdc; Hewlett-Packard Co. p/n 0180-0025			4		0.8	16.0	4-5	C17, C19, C20, C31
Pl	H		5910-228-9571 CAPACITOR, FIXED, ELECTROLYTIC: 20 uf; 450 wvdc; Hewlett-Packard Co p/n 0180-0011			1		0.3	4.0	4-5	C28

SOURCE CODE				FEDERAL STOCK NUMBER	DESIGNATION BY MODEL	DESCRIPTION	UNIT OF ISSUE	EXP	QTY IN UNIT	DIRECT SUPPORT	GENERAL SUPPORT	DEPOT	ILLUSTRATION	
													FIGURE NO.	ITEM NO.
A	B	C	D											
						AN/USM-205 (continued)								
P1	H			5910-082-4654		CAPACITOR, FIXED, ELECTROLYTIC: 35 uf; 6 wvdc; Sprague Electric Co p/n 30D156G006BB4,			1		0.2	3.0	C35	
P1	H					CAPACITOR, FIXED, ELECTROLYTIC: 80 uf; 300 wvdc; P. R. Mallory & Co. Inc. p/n FP128-103481 L4SA46-A181			1		0.2	3.0	C39	
P1	H			5910-892-7814		CAPACITOR, FIXED, ELECTROLYTIC: 50 uf; 50 wvdc; P. R. Mallory & Co. West Coast Laboratories type TC39 no. 95264,			2		0.3	6.0	C43, C44	
P1	H			5910-280-5181		CAPACITOR, FIXED, ELECTROLYTIC: 10 mf 450 wvdc; Aerovox Corp Pacific Coast Div p/n PRS-EP-450V-10MF			1		0.2	3.0	C50	
P1	H			5910-225-6492		CAPACITOR, FIXED, ELECTROLYTIC: 10 uf; 12 wvdc; Sprague Electric Co. p/n 30D106G012BA4			1		0.3	4.0	C54	
P1	H					CAPACITOR, FIXED, MICA DIELECTRIC: 10,000 pf ±10%; 300 wvdc; Elmenco Products Co p/n RDM30F103K3S, L4SA46-A044			3		0.3	9.0	C4, C6, C9	
P1	H					CAPACITOR, FIXED, MICA DIELECTRIC: 4,700 pf ±10%; 500 wvdc; Sangamo Electric Co Pickens Div p/n RDM30E472K, L4SA46-A240			1		0.2	3.0	C14	
P1	H					CAPACITOR, FIXED, MICA DIELECTRIC: 820 pf ±5%; 500 wvdc; Sangamo Electric Co Pickens Div p/n RCM20E822J, L4SA46-A242			1		0.2	3.0	C32	
P1	H			5910-225-6510		CAPACITOR, FIXED, MICA DIELECTRIC: 390 pf ±10%; 500 wvdc; Hewlett- Packard Co. p/n 0140-0030			2		0.3	6.0	C45, C46	
P1	H					CAPACITOR, FIXED, MICA DIELECTRIC: 22 pf ±5%; 500 wvdc; Sangamo Electric Co. Pickens Div p/n RCM15E220J, L4SA46-A172			1		0.2	3.0	C56	

SOURCE CODE				FEDERAL STOCK NUMBER	DESIGNATION BY MODEL	DESCRIPTION	UNIT OF ISSUE	EXP	QTY IN UNIT	DIRECT SUPPORT	GENERAL SUPPORT	DEPOT	ILLUSTRATION	
													FIGURE NO.	ITEM NO.
A	B	C	D											
						AN/USM-205 (continued)								
	FLH			5910-814-7179		CAPACITOR, FIXED, PAPER DIELECTRIC: 220,000 pf ±10%; 400 wvdc; Sprague Electric Co. p/n 160P22494,			2		0.3	6.0		C11, C18
	PLH			5910-819-2577		CAPACITOR, FIXED, PAPER DIELECTRIC: 0.1 uf ±10%; 400 wvdc; Hewlett-Packard Co. p/n 0160-0013			3		0.3	9.0		C13, C36, C40
	PLH			5910-822-7546		CAPACITOR, FIXED, PAPER DIELECTRIC: 4 uf ±10%; 600 wvdc; Sangamo Electric Co Pickens Div p/n 4106-4			1		0.2	3.0		C22
	PLH			5910-879-9804		CAPACITOR, FIXED, PAPER DIELECTRIC: 0.5 uf ±10%; 400 wvdc; Cornell-Dubilier Elect Corp p/n PKM4P5			1		0.2	3.0		C27
	PLH			5910-642-6259		CAPACITOR, FIXED, PAPER DIELECTRIC: 33,000 pf ±10%; 600 wvdc; Hewlett-Packard Co. p/n 0160-0004			1		0.2	3.0		C55
	PLH			5910-721-1783		CAPACITOR, FIXED, PLASTIC DIELECTRIC: 1 uf ±5%; 200 wvdc; Hewlett-Packard Co p/n 0170-0018			1		0.2	3.0		C33
	PLH					CAPACITOR, VARIABLE, AIR DIELECTRIC: 3 sections; 603 pf maximum; Hewlett-Packard Co. p/n 0121-0015, L4SA46-A126			1		0.3	5.0	4-5	C1A, C1B, C1C
	PLH			5910-866-5544		CAPACITOR, VARIABLE, AIR DIELECTRIC: 4 sections; 12.4-535.1 pf; Hewlett-Packard Co p/n 0121-0004			1		0.4	12.0	4-5	C2A, C2B
	PLH			5910-721-1731		CAPACITOR, VARIABLE, CERAMIC DIELECTRIC: 5-25 pf; 500 wvdc; Hewlett-Packard Co. p/n 0130-0012			2		0.3	6.0	4-5	C3, C42
	PLH			5910-871-3388		CAPACITOR, VARIABLE, CERAMIC DIELECTRIC: 7-45 pf; 500 wvdc; Erie Technological Products Inc. p/n 503-000-D2PO-33R,			1		0.2	3.0	4-5	C23

SOURCE CODE				FEDERAL STOCK NUMBER	DESIGNATION BY MODEL	DESCRIPTION	UNIT OF ISSUE	EXP	QTY IN UNIT	DIRECT SUPPORT	GENERAL SUPPORT	DEPOT	ILLUSTRATION	
													FIGURE NO.	ITEM NO.
A	B	C	D											
						AN/USM-205 (continued)								
				PLH	5910-578-5543				1		0.2	3.0	4-5	C24
				PLH	5910-669-3130				1		0.2	3.0		C25
				PLH	5950-575-0839				1		0.2	3.0		L1
				PLH	5950-575-0841				1		0.2	3.0		L5
				PLH	5950-808-8135				1		0.2	3.0		L9
				PLH	6625-777-7405				1		0.2	3.0		
				PLH	3040-900-0430				1		0.2	3.0		
				PLH	6625-869-3013				1		0.3	6.0		
				PLH	6625-880-3948				1		0.3	6.0		

SOURCE CODE	FEDERAL STOCK NUMBER			DESIGNATION BY MODEL	DESCRIPTION	UNIT OF ISSUE	EXP	QTY IN UNIT	DIRECT SUPPORT	GENERAL SUPPORT	DEPOT	ILLUSTRATION	
												FIGURE NO.	ITEM NO.
A	B	C	D										
					AN/USM-205 (continued)								
PLH					DIAL, SCALE: aluminum; 6.0 in dia by 0.062 in th; 0.750 dia center hole; mounting data; three 0.125 in dia mtg holes spaced equally on 1.0 in dia circle; Hewlett-Packard Co p/n 65A-40A, L4SA46-A096			1		0.2	3.0		
PL0	6625-759-7436				DIVIDER, VOLTAGE: MX-6122/U			1		0.3	5.0		
P0	5960-262-1357				ELECTRON TUBE: MIL type 5654/6AK5W			6		4.4	600.0	4-5	V1, V2, V3, V4, V5, V16
P0	5960-834-3368				ELECTRON TUBE: EIA type no. 6L6GC			2		5.8	200.0	4-5	V6, V7
P0	5960-100-5273				ELECTRON TUBE: EIA type no. 6SQ7			1		2.2	100.0	4-5	V8
P0	5960-557-6929				ELECTRON TUBE: EIA type no. 0A3			1		4.4	100.0	4-5	V9
P0	5960-817-7100				ELECTRON TUBE: EIA type no. 5U4GAB			1		2.5	100.0	4-5	V10
P0	5960-100-5268				ELECTRON TUBE: MIL type 6SJ7Y			1		1.7	100.0	4-5	V11
P0					ELECTRON TUBE: EIA type no. 6EW6, L4SA46-A153			2		2.9	200.0	4-5	V13, V14
P0	5960-617-9075				ELECTRON TUBE: EIA type no. 6AG7			2		5.8	200.0	4-5	V12, V15
P0	5920-295-9074				FUSE, CARTRIDGE: 2 amps; 125 vac; slow-blow; Bussman Mfg Div of McGraw-Edison Co p/n MDLE			1		1.4	50.0	4-6	F1
PLH	5920-881-4636				FUSE HOLDER: Littelfuse Inc p/n 342014			1		0.2	3.0		XF1
PLH	3020-808-1093				GEAR, BEVEL: straight type; 18 teeth; 20 degree pressure angle; 0.843 in od by 0.531 in lg overall; Hewlett-Packard Co. p/n 26A-100G			1		0.2	3.0		

SOURCE CODE				FEDERAL STOCK NUMBER	DESIGNATION BY MODEL	DESCRIPTION	UNIT OF ISSUE	EXP	QTY IN UNIT	DIRECT SUPPORT	GENERAL SUPPORT	DEPOT	ILLUSTRATION	
A	B	C	D										FIGURE NO.	ITEM NO.
						AN/USM-205 (continued)								
	FLH			6625-777-2078		GEAR, BEVEL: straight type; 36 teeth; 20 degree pressure angle; 1.5 in od by 0.531 lg over-all; mounting data; 2 no. 8-32 thread size tapped holes; holes spaced 90 degrees apart around gear centerline; Hewlett-Packard Co. p/n 26A-100F			1		0.2	3.0		
	FLH			5970-911-4835		INSULATOR, STANDOFF: plastic; output terminal post's; Hewlett-Packard Co. p/n 0340-0086			1		0.2	4.0		
	FLH			5970-911-4828		INSULATOR, STANDOFF: plastic; output terminal post's; Hewlett-Packard Co. p/n 0340-0090			1		0.2	4.0		
	FLO					KNOB: amplitude control; Hewlett-Packard Co p/n 0370-0032, L4SA46-A012			1		0.2	4.0		
	FLO					KNOB: rms volts-db; frequency; Hewlett-Packard Co. p/n 0370-0035, L4SA46-A013			2		0.2	4.0		
	FLO					KNOB: tuning; Hewlett-Packard Co. p/n 0370-0038, L4SA46-A014			2		0.3	8.0		
	FLO			6240-617-1488		LAMP, INCANDESCENT: 6.3 v; 0.15 amps; bipin base; General Elect Co lamp no. 12			1		0.4	50.0		DS1
	FLO			6240-151-4914		LAMP, INCANDESCENT: 250 v; 10 w; General Electric Co p/n 8A/S6-12 v			1		0.3	8.0	4-6	DS2 or R80
	FLH			6250-756-0214		LAMPHOLDER: Drake Mfg Co. p/n 2020E-AE			1		0.2	5.0		XDS1
	FLH					LAMPHOLDER: Drake Mfg Co. p/n 4309-016, L4SA46-A212			1		0.2	3.0		XDS2
	FLO			6210-729-9081		LENS, INDICATOR LIGHT: power on-off; Drake Mfg Co p/n 14L15			1		0.2	5.0		

SOURCE CODE	FEDERAL STOCK NUMBER				DESIGNATION BY MODEL	DESCRIPTION	UNIT OF ISSUE	EXP	QTY IN UNIT	DIRECT SUPPORT	GENERAL SUPPORT	DEPOT	ILLUSTRATION	
	A	B	C	D									FIGURE NO.	ITEM NO.
						AN/USM-205 (continued)								
						NUT, SHEET SPRING: accommodates no 8Z sheet metal screw; secures rear cover; Tinnerman Products Co p/n C7852-8Z-3, L4SA46-A003			4		0.4	12.0		
						PLUG, TIP: medium banana contact element; Ucinite Co p/n 152239			6		0.4	12.0		
						POST, BINDING: color coded black; 600 ohm output post; Hewlett- Packard Co. p/n 1510-0006			1		0.2	5.0		
						POST, BINDING: color coded red; 600 ohm output post; Hewlett-Packard part no 1510-0007			1		0.2	5.0		
						PRINTED CIRCUIT BOARD: includes three riveted mounting brackets; dimen- sions excluding brackets; 12.750 in lg by 1.625 in H by 0.062 in th; Hewlett-Packard Co p/n 65A-75K-1			1		0.2	3.0		
						PRINTED CIRCUIT BOARD: bakelite, with copperclad one side; 4.875 in lg by 3.125 in wd by 0.062 in th; Hewlett-Packard Co. p/n 65A-65A-1			1		0.2	3.0		
						PRINTED CIRCUIT BOARD: copperclad one side; includes two aluminum mounting brackets; 3.750 in lg by 0.062 in th by 1.625 in high o/a; Hewlett-Packard Co. p/n 65A-75J-1			1		0.2	3.0		
						REACTOR, FIXED: Hewlett-Packard Co. p/n 9110-0002			1		0.2	3.0		L7
						RESISTOR, CURRENT REGULATING: Amperite Co p/n 12-4			1		0.3	8.0	4-5	V17
						RESISTOR, FIXED, COMPOSITION: MIL type RC20GF224J			1		0.2	3.0		R15
						RESISTOR, FIXED, COMPOSITION: MIL type RC20GF124J			1		0.2	3.0		R16

SOURCE CODE				FEDERAL STOCK NUMBER	DESIGNATION BY MODEL	DESCRIPTION	UNIT OF ISSUE	EXP	QTY IN UNIT	DIRECT SUPPORT	GENERAL SUPPORT	DEPOT	ILLUSTRATION	
													FIGURE NO.	ITEM NO.
A	B	C	D											
				AN/USM-205 (continued)										
PLH				5905-299-2001		RESISTOR, FIXED, COMPOSITION: MIL type RC32GF124J			1		0.2	3.0	R36	
PLH				5905-299-2013		RESISTOR, FIXED, COMPOSITION: MIL type RC32GF473J			1		0.2	3.0	R43	
PLH				5905-299-2011		RESISTOR, FIXED, COMPOSITION: MIL type RC32GF563J			1		0.3	3.0	R44	
PLH				5905-299-2005		RESISTOR, FIXED, COMPOSITION: MIL type RC32GF823J			1		0.2	3.0	R45	
PLH				5905-279-1724		RESISTOR, FIXED, COMPOSITION: MIL type RC32GF151J			1		0.3	3.0	R50	
PLH						RESISTOR, FIXED, WIREWOUND: 3,000 ohms ±10%; 10 w; Hewlett-Packard Co p/n 0816-0002, L4SA46-A204			1		0.2	3.0	R51A	
PLH				5905-279-2286		RESISTOR, FIXED, COMPOSITION: MIL type RC42GF821J			1		0.2	3.0	R51B	
PLH				5905-279-1897		RESISTOR, FIXED, COMPOSITION: MIL type RC20GF560J			3		0.3	9.0	R56, R63 R81	
PLH				5905-192-3971		RESISTOR, FIXED, COMPOSITION: MIL type RC20GF331J			2		0.3		R58, R62	
PLH				5905-299-2023		RESISTOR, FIXED, COMPOSITION: MIL type RC32GF183J			2		0.3	6.0	R60, R100	
PLH				5905-279-3494		RESISTOR, FIXED, COMPOSITION: MIL type RC20GF823J			2		0.3		R61, R93	
PLH				5905-279-2544		RESISTOR, FIXED, COMPOSITION: MIL type RC32GF510J			1		0.2	3.0	R67	
PLH				5905-279-2553		RESISTOR, FIXED, COMPOSITION: MIL type RC32GF122J			2		0.3	6.0	R68, R103	
PLH				5905-279-3506		RESISTOR, FIXED, COMPOSITION: MIL type RC20GF332J			1		0.2	3.0	R69	

SOURCE CODE				FEDERAL STOCK NUMBER	DESIGNATION BY MODEL	DESCRIPTION	UNIT OF ISSUE	EXP	QTY IN UNIT	DIRECT SUPPORT	GENERAL SUPPORT	DEPOT	ILLUSTRATION	
A	B	C	D	FIGURE NO.	ITEM NO.									
						AN/USM-205 (continued)								
	PLH			5905-190-8865		RESISTOR, FIXED, COMPOSITION: MIL type RC20GF274J			2		0.3	6.0		R17, R66
	PLH			5905-299-2040		RESISTOR, FIXED, COMPOSITION: MIL type RC32GF472J			2		0.3	6.0		R18, R64
	PLH			5905-192-0660		RESISTOR, FIXED, COMPOSITION: MIL type RC20GF184J			1		0.2	3.0		R19
	PLH			5905-252-4018		RESISTOR, FIXED, COMPOSITION: MIL type RC20GF470J (Item nos. R21, R87, R94, R99, R101)			5		0.4	15.0		See desc column
	PLH			5905-279-2650		RESISTOR, FIXED, COMPOSITION: MIL type RC32GF562J			2		0.3	6.0		R22, R65
	PLH			5905-171-2004		RESISTOR, FIXED, COMPOSITION: MIL type RC20GF223J			2		0.3	6.0		R23, R79
	PLH			5905-279-3513		RESISTOR, FIXED, COMPOSITION: MIL type RC20GF221J			3		0.3	9.0		R24, R72, R73
	PLH			5905-185-8510		RESISTOR, FIXED, COMPOSITION: MIL type RC20GF103J			1		0.2	3.0		R26
	PLH			5905-299-2003		RESISTOR, FIXED, COMPOSITION: MIL type RC32GF104J			3		0.3	9.0		R27, R38, R39
	PLH			5905-192-3973		RESISTOR, FIXED, COMPOSITION: MIL type RC20GF471J			2		0.3	6.0		R30, R31
	PLH			5905-279-1697		RESISTOR, FIXED, COMPOSITION: MIL type RC32GF125J			1		0.3	3.0		R32
	PLH			5905-185-8516		RESISTOR, FIXED, COMPOSITION: MIL type RC42GF103J			2		0.3	6.0		R33, R59
	PLH			5905-299-2000		RESISTOR, FIXED, COMPOSITION: MIL type RC32GF224J			2		0.3	6.0		R34, R49

SOURCE CODE				FEDERAL STOCK NUMBER	DESIGNATION BY MODEL	DESCRIPTION	UNIT OF ISSUE	EXP	QTY IN UNIT	DIRECT SUPPORT	GENERAL SUPPORT	DEPOT	ILLUSTRATION	
													FIGURE NO.	ITEM NO.
A	B	C	D											
						AN/USM-205 (continued)								
	PLH			5905-190-8889		RESISTOR, FIXED, COMPOSITION: MIL type RC20GF101J			1		0.2	3.0		R70
	PLH			5905-279-2515		RESISTOR, FIXED, COMPOSITION: MIL type RC20GF474J			3		0.3	9.0		R71, R96, R97
	PLH			5905-171-1999		RESISTOR, FIXED, COMPOSITION: MIL type RC20GF821J			1		0.2	3.0		R74
	PLH			5905-299-2053		RESISTOR, FIXED, COMPOSITION: MIL type RC32GF221J			2		0.3	6.0		R75, R76
	PLH			5905-195-6806		RESISTOR, FIXED, COMPOSITION: MIL type RC20GF102J			1		0.2	3.0		R78
	PLH			5905-254-9201		RESISTOR, FIXED, COMPOSITION: MIL type RC20GF473J			1		0.2	3.0		R83
	PLH			5905-279-2626		RESISTOR, FIXED, COMPOSITION: MIL type RC32GF681J			3		0.3	9.0		R84, R85, R102
	PLH			5905-279-2628		RESISTOR, FIXED, COMPOSITION: MIL type RC32GF271J			1		0.3	3.0		R86
	PLH			5905-299-2022		RESISTOR, FIXED, COMPOSITION: MIL type RC32GF223J			1		0.2	3.0		R88
	PLH			5905-279-2028		RESISTOR, FIXED, COMPOSITION: MIL type RC42GF682J			2		0.3	6.0		R89, R91
	PLH			5905-279-1894		RESISTOR, FIXED, COMPOSITION: MIL type RC20GF820J			1		0.2	3.0		R90
	PLH			5905-190-8885		RESISTOR, FIXED, COMPOSITION: MIL type RC20GF225J			1		0.2	3.0		R92
	PLH			5905-299-1541		RESISTOR, FIXED, COMPOSITION: MIL type RC20GF151J			1		0.2	3.0		R95
	PLH			5905-279-1883		RESISTOR, FIXED, COMPOSITION: MIL type RC20GF335J			1		0.2	3.0		R98

SOURCE CODE				FEDERAL STOCK NUMBER	DESIGNATION BY MODEL	DESCRIPTION	UNIT OF ISSUE	EXP	QTY IN UNIT	DIRECT SUPPORT	GENERAL SUPPORT	DEPOT	ILLUSTRATION	
A	B	C	D										FIGURE NO.	ITEM NO.
						AN/USM-205 (continued)								
	PL	H		5905-840-3265		RESISTOR, FIXED, FILM: 495 ohms $\pm 1\%$; 1/2 w; Hewlett-Packard Co. p/n 0727-0076,			3		0.3	9.0		R3, R4, R6
	PL	H		5905-592-8257		RESISTOR, FIXED, FILM: 45 ohms $\pm 1\%$; 1/2 w; Mepeco Division p/n C-20-R-45; (Note: used in series with R3, R4, and R6)			3		0.3	9.0		R3A, R4A, R6A
	PL	H		5905-034-1279		RESISTOR, FIXED, WIREWOUND: 12 ohms $\pm 10\%$; 10 w; Hewlett-Packard Co. p/n 0816-0010			1		0.2	3.0		R82
	PL	H		5905-853-4863		RESISTOR, VARIABLE, COMPOSITION: 1,000 ohms $\pm 20\%$; 1/2 w; Hewlett-Packard Co. p/n 2100-0036			1		0.2	3.0		R25
	PL	H		5905-549-1651		RESISTOR, VARIABLE, COMPOSITION: 50,000 ohms $\pm 20\%$; 1/2 w; Hewlett-Packard Co. p/n 2100-0013			1		0.2	3.0	4-6	R35
	PL	H		5905-850-8398		RESISTOR, VARIABLE, COMPOSITION: linear taper; 10,000 ohms $\pm 30\%$; 1/3 w; Hewlett-Packard Co. p/n 2100-0167			1		0.2	3.0	4-6	R53
	PL	H				RESISTOR, VARIABLE, COMPOSITION: 500 ohms $\pm 10\%$; 1/2 w; Centralab Div of Globe Union Inc. p/n BA811-1190, L4SA46-A027			1		0.2	5.0	4-6	R55
	PL	H				RESISTOR, VARIABLE, COMPOSITION: 500 ohms $\pm 20\%$; 0.15 w; Hewlett-Packard Co, part no 2100-0151, L4SA46-A260			1		0.2	3.0	4-6	R77
	PL	H				RESISTOR, VARIABLE, wirewound; 25 ohms $\pm 10\%$; 5 w; Hewlett-Packard Co. p/n 2100-0870, L4SA46-A207			1		0.2	3.0	4-6	R42

SOURCE CODE				FEDERAL STOCK NUMBER	DESIGNATION BY MODEL	DESCRIPTION	UNIT OF ISSUE	EXP	QTY IN UNIT	DIRECT SUPPORT	GENERAL SUPPORT	DEPOT	ILLUSTRATION		
A	B	C	D										FIGURE NO.	ITEM NO.	
						AN/USM-205 (continued)									
	FLH			5905-257-7493		RESISTOR, VARIABLE: wirewound; 5,000 ohms $\pm 10\%$; 2 w; Hewlett-Packard Co. p/n 2100-0006			1		0.2	4.0	4-5	R46	
	FLH					RETAINER, CAPACITOR: 4 slots; 2.187 in lg by 1.537 in wd by 0.062 in th; Hewlett-Packard Co p/n 1520-0001, L4SA46-A170			2		0.3	6.0			
	FLH					RETAINER, CAPACITOR: 3 slots; 1.875 in lg by 1.343 in wd by 0.062 in th; Hewlett-Packard Co. p/n 1520-0002, L4SA46-A171			2		0.2	6.0			
	FLH					SCREW, TAPPING, THREAD FORMING: no 8; 3/8 in lg; stainless steel; secures rear cover; Federal Screw Products Co item; Hewlett-Packard Co p/n 0628-0002, L4SA46-A004			2		0.5	6.0			
	FLH			5960-059-9996		SEMICONDUCTOR DEVICE, DIODE: Hewlett-Packard Co. p/n 1900-0011			3		0.6	21.0			CR1, CR2, CR3
	FLH					SETSCREW: no. 8-32 threadsize; 0.187 in lg; headless; cup point; Hewlett-Packard Co part no 3030-0001, L4SA46-A064			16		1.0	48.0			
	FLH			5935-856-6987		SOCKET, ELECTRON TUBE: Cinch Mfg Co. and H. B. Jones Div. p/n 111-51-11-069,			3		0.3	9.0			XV1, XV2, XV3
	FLH			5935-865-6957		SOCKET, ELECTRON TUBE: Elco Corp part no 04-703-05 (Item nos. XV4, XV5, XV13, XV14, XV16)			5		0.4	15.0			See desc column
	FLH			5935-882-6455		SOCKET, ELECTRON TUBE: Elco Corp p/n 101-12-11-051 (Item nos. XV6, thru XV12, XV15, RT1)			9		0.7	27.0			See desc column
	FLH			5935-636-5792		SOCKET, TURRET ASSEMBLY: Vector Electronic Co p/n 10-0-9T			1		0.2	3.0			

SOURCE CODE				FEDERAL STOCK NUMBER	DESIGNATION BY MODEL	DESCRIPTION	UNIT OF ISSUE	EXP	QTY IN UNIT	DIRECT SUPPORT	GENERAL SUPPORT	DEPOT	ILLUSTRATION	
A	B	C	D										FIGURE NO.	ITEM NO.
						AN/USM-205 (continued)								
	PL	H		5340-849-9307		SPRING, HELICAL, COMPRESSION: 0.375 in free overall length of spring by 0.250 in free od of spring; Hewlett-Packard Co. p/n 1460-0063			1		0.2	3.0		
	PL	H		5340-594-0498		SPRING, HELICAL TORSION: steel; cadmium plated finish; 0.500 in free length of spring by 0.332 in od; Hewlett-Packard Co p/n 1460-0003			1		0.2	3.0		
	PL	H				SUPPRESSOR, PARASITIC: 0.2 uh; 4 turns no 30 awg wirewound over 220,000 ohms; 1 w resistor; Hewlett-Packard Co. p/n 65A-60H, L4SA46-A226			1		0.2	3.0		L6
	PL	H				SUPPRESSOR, PARASITIC: 8 uh; 46 turns no 36 awg wound over 470,000 ohm resistor; 1 w; Hewlett-Packard Co. part no 65A-60G, L4SA46-A262			1		0.2	3.0		L8
	PL	H		5930-786-8463		SWITCH ASSEMBLY, ROTARY: fully assembled with discreet parts; Hewlett-Packard Co. p/n 65A-19WH			1		0.4	10.0	4-6	S1A
	PL	H		6625-786-3542		SWITCH ASSEMBLY, ROTARY: 4.875 in lg over-all; 1.593 in dia over-all; 0.375-32 thread size of bushing; fully assembled with discrete parts; Hewlett-Packard Co p/n 65A-19WL,			1		0.8	36.0	4-6	S1B
	P	H		5930-729-8375		SWITCH, TOGGLE: SPST; Arrow-Hart and Hegeman Electric Co p/n 80994H			1		0.2	5.0		S2
	PL	H		5940-280-0665		TERMINAL BOARD: 3 solder lug terminals; 1.125 in lg by 0.375 in wd by 0.062 in th; H. B. Jones Div of Cinch Mfg Co. p/n 332-14-03-011			1		0.2	3.0		

AIV-20

SOURCE CODE				FEDERAL STOCK NUMBER	DESIGNATION BY MODEL	DESCRIPTION	UNIT OF ISSUE	EXP	QTY IN UNIT	DIRECT SUPPORT	GENERAL SUPPORT	DEPOT	ILLUSTRATION	
A	B	C	D										FIGURE NO.	ITEM NO.
						AN/USM-205 (continued)								
	PL	H		5940-063-8543		TERMINAL BOARD: 5 solder lug terminals; 1.875 in lg by 0.375 in wd by 0.062 in h; H. B. Jones Div of Cinch Mfg Co p/n 332-14-05-035			2		0.3	6.0		
	PL	H		5940-715-2731		TERMINAL BOARD: 7 solder lug terminals; 2.625 in lg by 0.375 in wd by 0.062 in th; H. B. Jones Division of Cinch Mfg Co. p/n 332-14-07-041			1		0.2	3.0		
	PL	H				TRANSFORMER, POWER, STEP-DOWN: 115/230 vac; 60 cps; single phase; Palo Alto Engineering Co. Inc. p/n 4002, L4SA46-A156			1		0.3	6.0	4-5	T1

HEADQUARTERS
DEPARTMENT OF THE ARMY
WASHINGTON, D. C., *1 March 1966*

TM 11-6625-665-15 is published for the use of all concerned.

By Order of the Secretary of the Army:

HAROLD K. JOHNSON,
General, United States Army,
Chief of Staff.

Official:

J. C. LAMBERT,
Major General, United States Army,
The Adjutant General.

DISTRIBUTION:

To redistributed in accordance with DA Form 12-32, Sec III (Unclas) requirements for Organizational maintenance, applicable to AN/FPA-15 and AN/FPA-16 systems.

